

ELR101 EARTH LEAKAGE RELAY

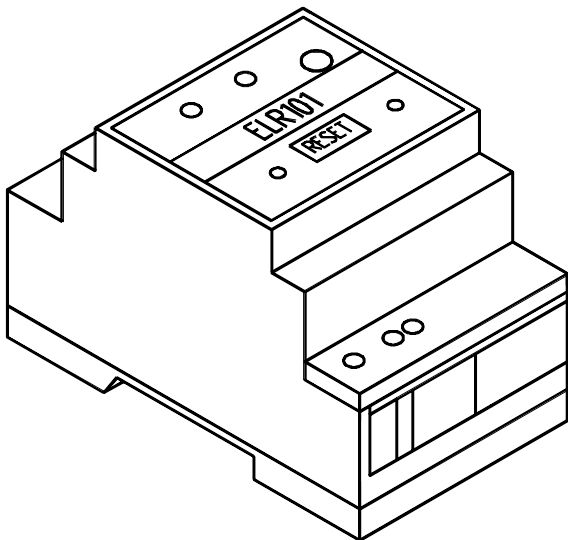

OPERATING INSTRUCTIONS JANUARY 1999

1. Safety

This instruction sheet gives details of safe installation and operation of the ELR101 Earth Leakage Relay. Safety may be impaired if the instructions are not followed. Labels on each device give details of equipment ratings for safe operation. Take time to examine all labels before commencing installation. Safety symbols on the device have specific meanings.



CAUTION
REFER TO USER
MANUAL



WARNING
RISK OF
ELECTRIC SHOCK

NOTE

The ELR101 is designed solely as a hazard warning device and **SHOULD NOT BE RELIED ON FOR LIFE PROTECTION.**

2. Cleaning The ELR101

The front panel of the ELR101 may be cleaned by wiping lightly with a soft, clean cloth. No solvents or cleaning agents should be used.

3. Description

The ELR101 triggers an alarm condition when the instantaneous sum of a number of currents exceeds a preset level. This TRIP condition is signalled on volt free, double pole, changeover relay contacts. An example of this is to control motor contactors in the event of current leakage to earth at the load.

A latching RESET switch is used to clear a TRIP event. This may be operated with or without an auxiliary supply to the ELR101.

A Test push-button provides a method of checking device operation and changeover of the relay contacts.

User controls allow the trigger level and an alarm delay to be preset to suit a wide range of installations.

4. Schematic

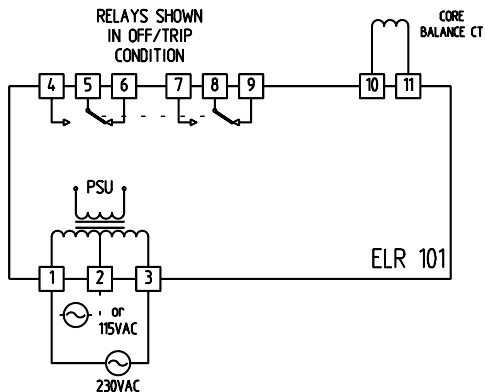

Figure 4.1 ELR101 Schematic Symbol

The ELR101 consists of three main isolated circuits; auxiliary mains supply, relay contacts and the microprocessor circuit with external core balance CT input. Isolation is provided at 2.5kV between each of these circuits. Figure 4.1 shows the relay contacts in the non-energised, fail safe state. This state is valid when the auxiliary supply is isolated (OFF) and when an excess out of balance current is detected (TRIP state).

5. Auxiliary Supply

An auxiliary supply is required to provide power for the microprocessor control/measurement circuit. Stable supplies of 230VAC $\pm 15\%$ or 115VAC $\pm 15\%$ should be used.

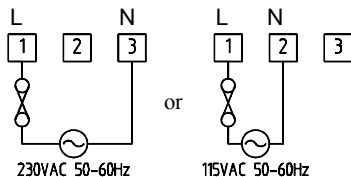

Figure 5.1 Auxiliary Mains Supply

The ELR101 should be protected by an external fuse (Figure 5.1). Under normal fault-free operation the ELR101 requires an average AC current not exceeding 35mA. The external fuse may protect other equipment within the installation. It should be rated at the total fault current for the system. Refer to the operating information for each device for individual protection current requirements. The ELR101 contains an internal fuse rated at 50mA (T). This fuse should not be replaced by unauthorised personnel.

6. Core Balance CTs

6.1 General

Core balance current transformers (CTs) are designed to monitor the instantaneous sum of currents (imbalance) in a number of conductors passed through the primary. This type of CT is normally rated for sensitivity to current imbalance, NOT the actual current carried by each conductor. A system with a load of 300A, for example, may be designed with a core balance CT rated at 3A sensitivity to detect earth leakage fault currents. When specifying a core-balance CT the internal core diameter should be selected to suit the size and number of conductors to be monitored. Smaller sensitivities require wound primaries with conductors terminated on top of the CT.

6.2 Suitable Types

A range of core balance CTs are available, designed specifically for operation with the ELR101. These have standard nominal sensitivities of 1A, 3A, 10A or 30A and accept a variety of conductor sizes. Other CTs may be provided to special order.

Part No	Sensitivity	ELR101 Range	Internal \varnothing
K.1029	100mA	30mA-120mA	Terminals
K.1028	300mA	100mA-360mA	Terminals
K.1027	1A	300mA-1.2A	Terminals
K.1025	1A	300mA-1.2A	23mm
K.1024	3A	1.0A-3.6A	37mm
K.1023	10A	3.0A-12.0A	55mm
K1020	10A	3.0A-12.0A	72mmx290mm
K.1022	30A	10.0A-36.0A	100mm
K.1021	30A	10.0A-36.0A	72mmx290mm

6.3 CT Connection

Primary conductors should be fed through the hole in the centre of the device as shown. It is essential each conductor passes through the device in the same direction (Supply to Load).

If monitoring Earth Leakage, each phase conductor (and neutral if it exists) should be monitored. Earth conductors including protective shielding should not be fed through the CT.

The secondary (output) terminals of the CT are labelled S1 and S2 these should be wired to the ELR101 terminals 10 and 11 respectively as shown in Figure 6.1. An Earth terminal (E) is provided for systems where earthing of the CT secondary is preferred. This is connected to S2 by the CT.

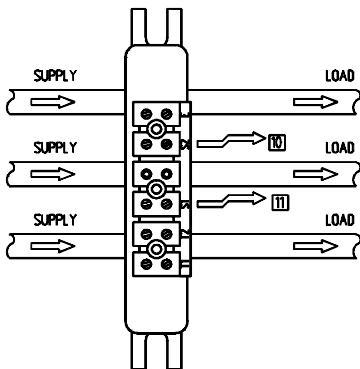

Figure 6.1 Wiring Of CT

The connections between the CT and the ELR101 should be kept as short as possible to minimise signal noise. It is recommended the ELR101 and the CT are kept within 1m of each other. For longer cable runs the use of screened/twisted cable is recommended in addition to ferrite beads to minimise electromagnetic interference.

6.4 Optional Test Winding

The core balance CT may be provided with an optional test winding allowing the CT/ELR101 system to be tested during commissioning or periodically after installation.

The test winding should be connected to an external resistor and switch as shown in Figure 4.1.

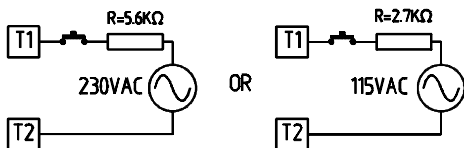

Figure 6.2 Wiring CT Test Winding

The N/O switch contacts should be rated at 230VAC, 1A and should not be held closed for longer than 1 min. The resistor should be rated at 250VAC, 10W. When the external switch is closed a current imbalance greater than 120% of the sensitivity of the CT is injected into the primary. The ELR101 will enter the TRIP state if the switch is closed for a period greater than the preset Delay time (ref Section 9).

7. Relay

7.1 Operation

A double pole change-over relay is used to signal the operating state of the ELR101. The relay has two states **RUN** and **OFF/TRIP**.

- **RUN** The current imbalance has not exceeded the Trip Level for a period greater than the Delay time and the auxiliary supply is ON.
- **OFF/TRIP** The current imbalance has exceeded the preset Level for a period greater than the preset Delay time or the auxiliary supply is isolated (OFF). This is the fail safe state

7.2 Contacts

The relay contacts are connected as shown in Figure 7.1 in each of the two operating states. Refer to the specification for contact ratings.

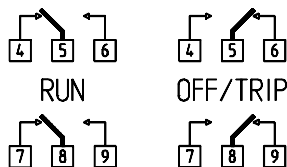

Figure 7.1 Relay Contacts

8. % Trip Level

%TRIP presets the current at which the ELR101 will enter the TRIP state as a **percentage of nominal sensitivity** rating for the CT used.

For example for a 3A sensitivity core balance CT, a preset Level of 30% will cause a TRIP state for imbalance currents greater than 1A.

To adjust the %TRIP level use a small screwdriver to rotate the selector until the arrow points to the required level.

9. Delay

The measurement stage of the ELR101 is filtered to prevent unwanted tripping due to noise, spikes etc. This filter has a maximum response time of 50mS, which occurs when the input current switches instantaneously, from zero to just above the Preset Trip Level. For larger input swings this time is proportionately reduced.

In addition to this response time the user may add a preset Delay to prevent short term current imbalances setting the Trip state. In order for a TRIP state to occur, the input circuit must respond to an imbalance current greater than the preset %TRIP level, for a continuous period greater than the Delay period. If the current falls below the preset % TRIP level for a period greater than 1ms the internal delay timer is reset to zero.

To adjust the Delay use a small screwdriver to rotate the selector until the arrow points to the required time.

10. Test

The TEST button on the front of the ELR101 allows the user to artificially set the TRIP state in order to carry out a system test. To enter a TRIP state press the TEST button for a period greater than the preset Delay period.

NOTE : Operation of the TEST button tests the ELR101 only. Refer to Section 6.4 for testing of the core balance CT and ELR101 together.

11. Reset

The RESET button switches the ELR101 from a latched TRIP state to the RUN state. Once reset, a full TRIP condition must re-occur before the unit enters the TRIP state again.

To reset a TRIP state press the RESET button ONCE only.

11.1 Reset With No Auxiliary Supply

The ELR101 remembers the position of the latching RESET switch during auxiliary power loss. If the RESET button is **PRESSED ONCE**, while the unit is isolated the RUN state will be restored when the supply is re-applied.

12. Specification

Aux Supply	230V or 115VAC $\pm 15\%$. 50-60Hz 5VA Internal Fuse 50mA (T) Isolation 2.5kV, 1 minute
Core Balance CT	Sensitivity Options - 0.1,0.3,1,3,10 or 30A
Relay Contacts	2 Pole Changeover, Isolation 2.5kV, 1 min 5A, 230VAC, 120W Resistive 2.5A, 230VAC, 75W Inductive
Input Response	50mS Max (Section 9)
Delay Preset	100ms - 10 seconds (Accuracy $\pm 5\%$)
Trip Preset	30% - 120% of CT Sensitivity Accuracy $\pm 10\%$ of preset value
Enclosure	DIN 43880 3-Modules, Noryl UL94V0
Rail	DIN EN 50022 - 35mm
Environment	
Operating	-10C - 60C < 75% RH Non Condensing
Storage	-25C - 70C < 85% RH Non Condensing

