



diris_a60_a_1_cat

Monitoring and managing energy for high/low voltage electrical installations

Function

DIRIS A60 is a measurement station which takes over all the functions of DIRIS A40 and which is enhanced by a history of harmful events for installation. A graphic representation of these harmful events is assimilated and provided to the user. All this information can be used and analysed remotely using free quality measurement software that can be downloaded on the site www.socomec.com.

Conformity to standards

- IEC 61557-12
- IEC 62053-22 class 0,5 S
- IEC 62053-23 class 2

Applications

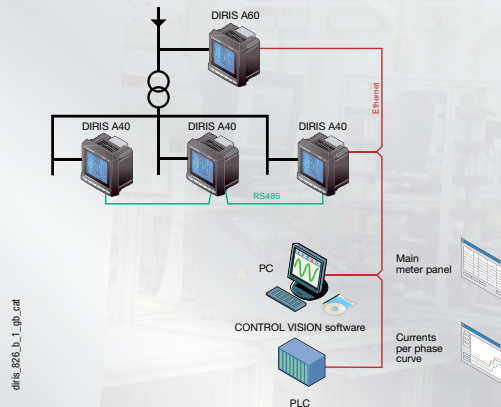

In addition to the functions of the DIRIS A40, the **DIRIS A60** also:

- shows the current and voltage unbalance
 - shows the tangent phi
 - stores the load curves (50 days with an interval of 10 minutes) for:
 - Active, reactive and apparent power: ΣP +/- ; ΣQ +/- , ΣS .
 - detects and stores the last 40 events concerning:
 - overvoltage
 - voltage dips
 - outages
 - overcurrent
- For each stored event, the DIRIS A60 records the relevant RMS 1/2 interval curves for the voltages V1, V2, V3, U12, U23, U31 and the currents I1, I2, I3, In, giving a total of 400 curves.

Other functions :

Multimeasurement

- Current
 - instantaneous: I1, I2, I3, In, Isystem,
 - maximum: I1, I2, I3, In
 - unbalance: I unb
- Voltages & frequency
 - instantaneous: U1, U2, U3, U12, U23, U31, F, Vsystem, Usystem
 - maximum: U1, U2, U3, U12, U23, U31, F
 - unbalance: U unb
- Powers
 - instantaneous: 3P, ΣP , 3Q, ΣQ , 3S, ΣS
 - mean maximum: ΣP , ΣQ , ΣS
 - predictive: ΣP , ΣQ , ΣS
- Power factor
 - instantaneous: 3PF, ΣPF
- Total tangent phi
 - maximum: ΣPF

- Temperatures⁽¹⁾
 - Internal
 - external via 3 PT100 sensors

Metering

- Active energy: +/- kWh
- Reactive energy: +/- kvarh
- Apparent energy: kVAh
- Hours: ☺

Harmonic analysis (level 63)

- Total harmonic distortion
 - Currents: thd I1, thd I2, thd I3, thd In
 - Phase-to-neutral voltage: thd U1, thd U2, thd U3
 - Phase to phase voltage: thd U12, thd U23, thd U31
- Individual
 - Currents: HI1, HI2, HI3, HIn
 - Phase-to-neutral voltage: HU1, HU2, HU3,
 - Phase to phase voltage: HU12, HU23, HU31

Events⁽¹⁾

- Alarms on all electrical values

Communications⁽¹⁾

- Analogue 0/4- 20 mA
- Digital RS485 (Jbus/Modbus & Profibus-DP)
- Ethernet (modbus/TCP or Jbus/Modbus RTU over TCP and Web server)
- Ethernet with RS485 gateway Jbus/Modbus RTU over TCP

Inputs / Outputs⁽¹⁾

- Pulse metering
- Control/command of devices
- Alarm report
- Pulse report

(1) Available as an option (see the following pages).

➔ Front panel



1. Backlit LCD screen.
2. Pushbutton for currents, temperatures and CT setup wiring correction.
3. Pushbutton for voltages and frequency.
4. Pushbutton for active, reactive, and apparent power and power factor.
5. Pushbutton for maximal and average current and power values.
6. Pushbutton for harmonics values.
7. Pushbutton for energies and hour run meter.

➔ Plug-in modules

DIRIS® A60

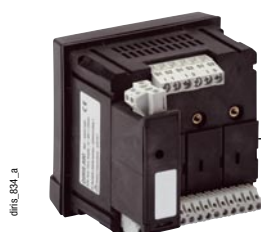

Pulse outputs

- 2 configurable pulse outputs (type, weight and duration) on \pm kWh, \pm kvarh and kVAh.



JBUS / MODBUS® communication

- RS485 link with JBUS / MODBUS® protocol (speed up to 38400 bauds).



PROFIBUS® DP communication

- RS485 link with PROFIBUS® DP protocol (speed up to 12 Mbauds).



Ethernet communication

- Ethernet link with MODBUS/TCP or JBUS/MODBUS RTU over TCP.



Ethernet communication with RS485 Gateway JBUS/MODBUS

- Ethernet link with MODBUS/TCP or JBUS/MODBUS RTU over TCP.
- Connection of 1 to 247 RS485 JBUS/MODBUS slaves.



Analogue outputs

- 2 modules may be connected at maximum, that is 4 analogue outputs. 2 outputs assignable to:
3I, In, 3V, 3U, F, \pm Σ P, \pm Σ Q, Σ S, Σ PFL/C, I sys, Vsys, Usys, Ppred, Q pred, Spred, internal T°C, T°C 1, T°C 2, T°C3 and to 17 VDC power supply.



2 inputs - 2 outputs

- A maximum of 3 modules may be connected, giving 6 inputs. 2 outputs assignable to :
- monitoring:
3I, In, 3V, 3U, F, \pm Σ P, \pm Σ Q, Σ S, Σ PFL/C, THD 3I, THD In, THD 3V, THD 3U, Ppred, Qpred, Spred, internal T°C, T°C 1, T°C2, T°C3 and hour meter,
- remote control,
- timed remote control,
- 2 inputs for pulses metering.



Temperature

- Temperature indication:
 - Internal
 - External sensor PT 100 (T°C 1)
 - External sensor PT 100 (T°C 2)
 - External sensor PT 100 (T°C 3)

➔ **DIRIS A60 - Accessories**

Current transformer
(see page XXX)



Current transformers



IP65 protection



Mounting kit for 144 x 96 mm cut out plate



➔ **Terminals**

DIRIS A60

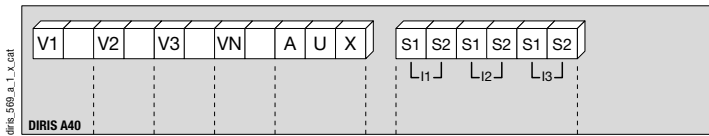

S1 - S2: Current inputs

AUX: auxiliary power supplies U_s
V1 - V2 - V3 - VN: voltage inputs

Communication module

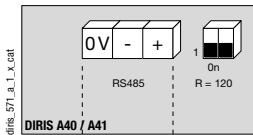

RS485 link.
 $R = 120 \Omega$: internal resistance for RS485 link.

2 inputs / 2 outputs module

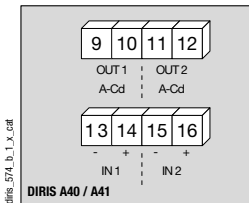

9 - 10: relay output no. 1.
11 - 12: relay output no. 2.
13 - 14: input no. 1.
15 - 16: input no. 2.

Ethernet module + RS485 gateway
JBUS/MODBUS

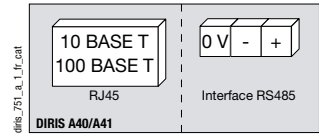

Ethernet Module

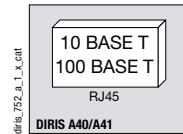

Pulse output module

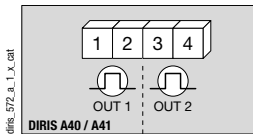

1 - 2: pulse output no. 1.
3 - 4: pulse output no. 2.

Temperature module

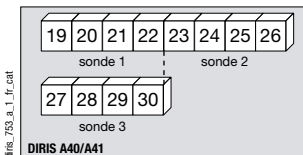

Analogue output module

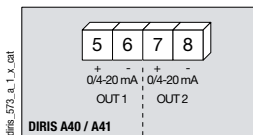

5 - 6: Analogue output no. 1.
7 - 8: Analogue output no. 2.

Characteristics

Current measurement on insulated inputs (TRMS)

CT primary	10000 A
CT secondary	1 or 5
Measurement range	0 ... 11 kA
Input consumption	≤ 0.1 VA
Measurement updating period	1 s
Accuracy	0.2 %
Sustained overload	6 A
Intermittent overload	10 I _n for 1 s

Voltage measurements (TRMS)

Direct measurement between phases	50 ... 700 VAC
Direct measurement between phase and neutral	28 ... 404 VAC
VT primary	500000 VAC
VT secondary	60, 100, 110, 173, 190 VAC
Frequency	50 / 60 Hz
Input consumption	≤ 0.1 VA
Measurement updating period	1 s
Accuracy	0.2 %
Sustained overload	760 VAC

Current-voltage product

Limitation for 1A CT	10000000
Limitation for 5A CT	10000000

Power measurement

Measurement updating period	1 s
Accuracy	0.5 %

Power factor measurement

Measurement updating period	1 s
Accuracy	0.5 %

Frequency measurement

Measurement range	45 ... 65 Hz
Measurement updating period	1 s
Accuracy	0.1 %

Energy accuracy

Active (according to IEC 62053-22)	class 0.5 S
Reactive (according to IEC 62053-23)	class 2

Auxiliary supply

Alternating voltage	110 ... 400 VAC
AC tolerance	± 10 %
Direct voltage	120 ... 350 VDC
DC tolerance	± 20 %
Frequency	50 / 60 Hz
Consumption	≤ 10 VA

Outputs (alarms / control)

Number of relays	2 ... 6
Type	250 VAC - 5 A - 1150 VA

Phototransistor inputs

Number	2 ... 6
Power supply	10 ... 30 VDC
Minimum signal width	10 ms
Minimum length between 2 impulses	18 ms
Type	phototransistor

Outputs (pulses)

Number of relays	2
Type	100 VDC - 0.5 A - 10 VA
Max. number of operations	≤ 10 ⁶

Outputs (analogue)

Number of outputs	2 ... 4
Type	insulated
Scale	0 / 4 ... 20 mA
Load resistance	600 Ω
Maximum current	30 mA

Communication

Link	RS485
Type	2 ... 3 half duplex wires
Protocol	JBUS/MODBUS® in RTU mode
JBUS/MODBUS® speed	1400 ... 38400 bauds
Protocol	PROFIBUS® DP
PROFIBUS® speed	9.8 kbauds ... 12 Mbauds

Ethernet communication

Connection	RJ45
Speed	10 base T / 100 base T
Protocol	MODBUS TCP or JBUS/MODBUS RTU over TCP

Temperature inputs

Type	PT100
Connection	2, 3 or 4 wires
Dynamic	- 20°C ... 150°C
Accuracy	+/- 1 digit
Maximum length	300 cm

Operating conditions

Operating temperature	- 10 ... + 55°C
Storage temperature	- 20 ... + 85°C
Relative humidity	95 %

Case

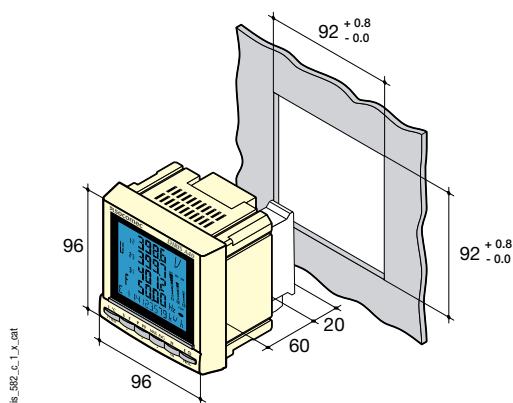

Type	panel mounting
Dimensions W x H x D	96 x 96 x 60 mm
Case protection index	IP30
Front protection rating	IP52
Display type	LCD
Terminal blocks type	fixed or pull-out
Voltage and other connection section	0.2 ... 2.5 mm ²
Current connection section	0.5 ... 6 mm ²
Weight	400 g

diris_a60_c_1_x_cat

➔ DIRIS A60 - Connection

Recommendation: While disconnecting the DIRIS, the secondaries of each current transformer must be short-circuited. This operation can be carried out automatically from a product in the SOCOMEC catalogue, PTI: Please consult us.

Low voltage balanced network for DIRIS A60

3/4 wires with 1 CT

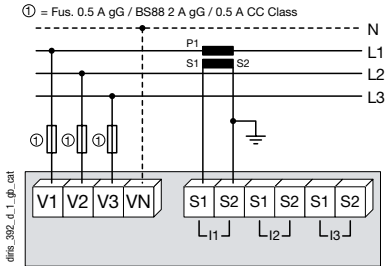

Use of 1 CT reduces by 0.5% the accuracy of the phases whose current is worked out by vector calculation.

Single phase

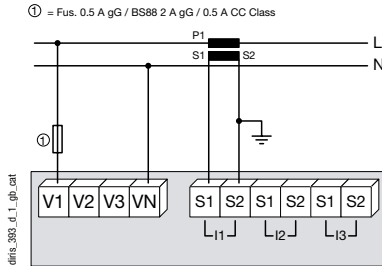

Two phase

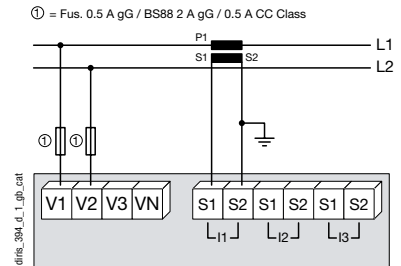

Low voltage unbalanced network for DIRIS A40

3/4 wires with 3 CTs

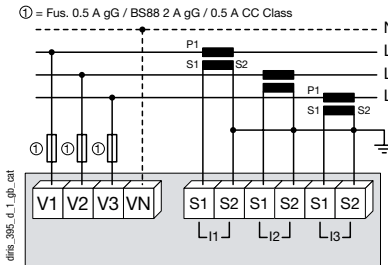

3 wires with 2 CTs

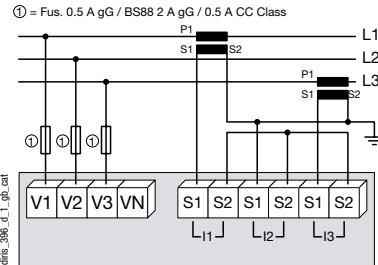

Use of 2 CTs reduces by 0.5% the accuracy of the phase whose current is worked out by vector calculation.

3 wires with 2 CTs

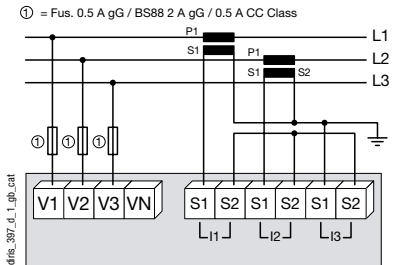

Use of 2 CTs reduces by 0.5% the accuracy of the phase whose current is worked out by vector calculation.

Additional information

Communication via RS485 link

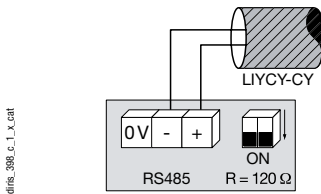

Connection of voltage transformer for HV networks

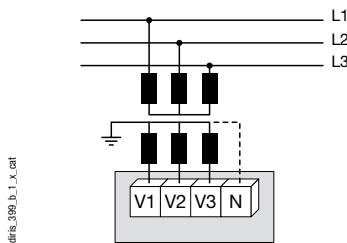

AC & DC auxiliary power supply

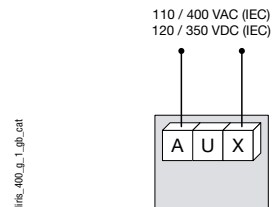

It is recommended that the auxiliary power supply must be protected by the use of 500 mA gG fuses.

References



diris_a60_a_1_cat

Standard device	DIRIS A60
Auxiliary power supply U_a	Reference
	4825 0207

Accessories

Description of accessories	Pack qty	Reference
IP65 protection	1	4825 0089
Panel mounting kit for a 144 x 96 mm cutout	1	4825 0088
Fuse combination switches for the protection of voltage inputs (type RM) 3 poles	4	5601 0018
Fuse combination switches for the protection of the auxiliary supply (type RM) 1 pole + neutral	6	5601 0017
Fuses type gG 10x38 0.5 A	10	6012 0000
Current transformers range		See page XXX

Plug-in modules ⁽¹⁾	Reference
Pulse outputs	4825 0090
RS485 JBUS / MODBUS [®] communication	4825 0092
Analogue outputs	4825 0093
2 inputs / 2 outputs	4825 0094
RS485 PROFIBUS [®] DP communication	4825 0205
Ethernet communication	4825 0203
Ethernet communication + RS485 gateway JBUS/MODBUS	4825 0204
Temperature inputs	4825 0206

(1) Ease of integration for additional functions (maximum 3).