

Energy Management Three-phase power analyzer with output modules Type WM22-DIN



- Class 0.5 (current/voltage)
- Three-phase power analyzer
- Back-lighted LCD
- 4 x 3 1/2 DGT instantaneous variables read out
- 7 1/2 DGT energy read-out
- Measurements of system and phase variables: W, Wdmd, var, VA, VAdmd, PF (cosφ), V, A, Hz, THD-A, THD-V
- Measurements of total energies: kWh, kvarh
- Measurements of partial energies: kWh, kvarh
- Energy measurements according to EN61036 and EN61268
- TRMS measurements of distorted wave forms (voltages/currents)
- Two basic models: direct connection 20(90)AAC, CT 5(10)AAC and VT connection

- Front dimensions: 9 DIN modules
- Analogue output by means of optional module (20mA or 10VDC)
- RS 422/485 Serial port by means of optional module
- Alarm output by means of optional module
- Dual pulse output by means of optional module
- Control of phase asymmetry

- Maximum value indication of W dmd and VA dmd (only 5A version); maximum value indication of A (only 90A version)
- Self power supply (available for some models only) or auxiliary power supply: 24V, 48V, 115V, 230V, 50-60Hz; 18 to 60VDC, 77 to 143VDC
- Degree of protection (front): IP 40

Product description

Three-phase power analyzer with built-in configuration key-pad; Particularly indicated for the analysis of main, secondary and energy metering electrical variables. Housing for DIN-rail or wall-mounting, IP40 (front) protection degree. Completely sealable housing. In case of direct connection up to 90A, the measuring input terminals are suitable for cables with a cross-section

area from 6 to 35 mm². The special design of the instrument's housing allows to add at any time the interface modules, even when the instrument is already installed. The following modules are available:

- for all versions: pulses output;
- only for the versions with auxiliary power supply: analogue output, RS485 port or alarm output.

How to order **WM22-DIN AV5 3 X X XX**

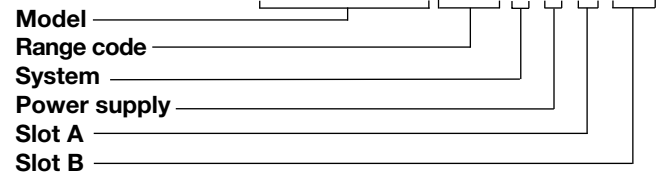

Type selection

Range Code	Power supply	Slot A (retransmission)	Slot B (retransmission)
Auxiliary Power Supply:			
AV0: 208V _{L-L} /20(90)AAC [3]	For all versions A: 24VAC -15+10%, 50-60Hz B: 48VAC -15+10%, 50-60Hz C: 115VAC -15+10%, 50-60Hz D: 230VAC -15+10%, 50-60Hz	X: None O: AO2900 module Dual open collector output Three operating modes: • two pulse outputs (kWh and kvarh); • one alarm output and one pulse output (kWh or kvarh) • one output which is remotely controlled by a serial port and one pulse output (kWh or kvarh)	Only with A-B-C-D-4 power supply XX: None A1: AO2920 module 0-20mADC analogue output V1: AO2921 module 0-10VDC analogue output S0: AR2950 module RS422/485 serial port
AV1: 400V _{L-L} /20(90)AAC [1]			
AV3: 660V _{L-L} /20(90)AAC [2]			
AV4: 208V _{L-L} /5(10)AAC [3]			
AV5: 400V _{L-L} /5(10)AAC [1]			
AV6: 100V _{L-L} /5(10)AAC [3]			
AV7: 660V _{L-L} /5(10)AAC [2]			
Self Power Supply:			
AV8: 208V _{L-L} /20(90)AAC [1]	Only for AV8 and AV9 versions X: Self Power Supply 400V _{L-L} -20+15%, 50-60Hz 208V _{L-L} -20+15%, 50-60Hz	R: AO2910 module. One relay output + one open collector output. Operation modes like module AO2900.	
AV9: 400V _{L-L} /20(90)AAC [1]			
System			
3 : Three-phase, balanced and unbalanced load with or without neutral			

[1] Un: -20+15% [2] Un: -30+15% [3] Un: -20+20%

Specifications are subject to change without notice

Input specifications

Number of inputs		Additional errors	Acc. to EN61036, EN61268
Current	3	Wave form	<1% (3 rd harmonic: 10%)
Voltage	4	Voltage asymmetry	< 0.5% (referred to Un)
Accuracy (display, RS485)	lb: 5A, I _{max} : 10A lb: 20A, I _{max} :90A Un: see previous page "Range code"	Magnetic induction	0 (up to 0.5 mT)
Current	from 0.003lb to 0.2lb: ±(0.5%RDG +3DGT) from 0.2lb to I _{max} : ±(0.5%RDG +1DGT)	HF Electromagnetic fields	< 1%
Voltage	in the range Un: ±(0,5% RDG + 1DGT)	Operation of accessories	0
Frequency	±0.1% RDG (50 to 60 Hz)	Temperature drift	≤200ppm/°C
Active power (@ 25°C ± 5°C, R.H. ≤ 90%)	±(1% RDG +1DGT). PF 1, 0.1lb to I _{max} , in the Un range; PF 0.5L, PF 0.8C, 0.2lb to I _{max} , in the Un range	Sampling rate	1000 samplings/s @ 50Hz
Reactive power (@ 25°C ± 5°C, R.H. ≤ 90%)	±(2% RDG +1DGT). sinφ 1, 0.05lb to I _{max} , in the Un range; sinφ 0.5L, sinφ 0.5C, 0.1lb to I _{max} , in the Un range	Display	Type Instantan. variables read-out Energies
Apparent power (@ 25°C ± 5°C, R.H. ≤ 90%)	±(1% RDG +1DGT). PF 1, 0.1lb to I _{max} , in the Un range	Max. and Min. indication	Back-lighted LCD 4x3 ¹ / ₂ DGT Total:1x7 ¹ / ₂ DGT Partial: 1x7 ¹ / ₂ DGT
Energies (@ 25°C ± 5°C, R.H. ≤ 90%)	Class 1 acc. to EN61036 Class 2 acc. to EN61268 lb: 5A, I _{max} : 10A 0.1lb: 500mA, Start up corrent: 20mA Un: see table "range code" lb: 20A, I _{max} : 90A 0.1lb: 2A, Start up current: 80mA Un: see table "range code"	Measurements	Max. 1999 (19999999), Min. 0
Harmonic distortion (@ 25°C ± 5°C, R.H. ≤ 90%)	±3% f.s. (f.s.: 100%) up to the 7 th harmonic; Un: see table "range code"	Coupling type	Current, voltage, power, energy, power factor, frequen- cy, harmonic distortion (see display specs). TRMS measurements of distorted wave forms. Direct
lb 5A	I _{min} : 500mA; I _{max} : 15Ap;	Crest factor	
lb 20A	I _{min} : 2A; I _{max} : 127Ap;	lb 5A	≤3 (15A max. peak)
		lb 20A	≤6 (127A max. peak)
		Current overload	
		5(10) A, for 10ms	300 A max, @ 50Hz
		5(10) A, for 500ms	200 A max, @ 50Hz
		5(10) A, permanent	10A, @ 50Hz
		20(90) A, for 10ms	2700A max, @ 50Hz
		20(90) A, permanent	90A, @ 50Hz
		Voltage overload	
		Permanent	1.2 Un
		For 1s	2 Un
		Input impedance	
		400V _{L-L} (AV1-AV5-AV9)	> 720KΩ
		208V _{L-L} (AV0-AV4-AV8)	> 720KΩ
		660V _{L-L} (AV3-AV7)	> 1.97MΩ
		100V _{L-L} (AV6)	> 400KΩ
		5(10) A (AV4-AV5-AV6-AV7)	< 0.3VA
		20(90) A (AV0-AV1-AV3-AV8-AV9)	< 4VA
		Frequency	50 to 60 Hz

Interface module specifications

Analogue outputs (on request)			the following ranges: 0 and 20mADC, 0 and 10VDC
Number of outputs	1	Response time	
Range	0 to 20 mADC (AO2920 module slot B, only for versions with auxiliary power supply) 0 to 10VDC (AO2921 module slot B, only for versions with auxiliary power supply)	System variables	V, W, VA, var, PF (cosφ)
Accuracy	±0.5% F.S.	FFT off, filter off	900ms
Temperature drift	≤ 300 ppm/ °C	FFT on, filter on	1.4s
Scaling factor	Programmable within the whole range of retransmission; it allows the retransmission of all the values included in	variables	THD-V, THD-A
		Filter off	3s
		Ripple	≤1% according to IEC 60688-1, EN 60688-1
		Load	
		20 mADC	≤ 500 Ω
		10 VDC	≥ 10 kΩ
		Insulation	By means of optocouplers, 2000 V _{RMS} between output and measuring input

Interface module specifications (cont.)

	2000 V _{RMS} between output and power supply input		
RS422/RS485 (on request)	AR2950 module	Insulation	According to DIN43864 By means of optocouplers, 2000 V _{RMS} outputs to measuring inputs, 2000 V _{RMS} output to supply input. Insulation between the two outputs: functional
Type	Multidrop bidirectional (static and dynamic variables)	Alarm output	1
Connections	2 or 4 wires, max. distance 1200m, termination directly on the module	Number of outputs	Up alarm, down alarm
Addresses	255, selectable by key-pad	Alarm type	phase asymmetry, phase loss.
Protocol	MODBUS/JBUS	Setpoint adjustment	0 to 100% of the electrical scale
Data (bidirectional)	Phase and system variables: see table "Display pages"	Hysteresis	0 to 100% of the electrical scale
Dynamic (reading only)	All the programming data, reset of energy, activation of static output.	On-time delay	0 to 255 seconds
Static (writing only)	Stored energy (EEPROM) max. 19.999.999 kWh/kvarh	Response time	
Data format	1 start bit, 8 data bit, no parity, 1 stop bit	system variables	V, W, VA, var, PF (cosφ)
Baud-rate	9600 bit/s	FFT off, filter off	700ms
Insulation	By means of optocouplers, 2000 V _{RMS} output to measuring inputs 2000 V _{RMS} output to supply input	FFT on, filter on	1.2s
		variables	THD-V, THD-A
		Filter off	3s
		Output type	Open collector (transistor NPN) V _{ON} 1.2 VDC / max. 100 mA V _{OFF} 30 VDC max.
Digital outputs (on request)		Insulation	By means of optocouplers, 2000 V _{RMS} output to measuring input, 2000 V _{RMS} output to supply input. Insulation between the two outputs: functional
AO2900 module	To be used as alarm, energy retransmission, or remote static outputs.	AO2910 module	Relay + open collector output. Working mode like AO2900.
	Three working modes are selectable:	Pulse output	like AO2900
	• two pulse outputs (kWh and kvarh);	Alarm output	like AO2900
	• one alarm output and one pulse output (kWh or kvarh)	Insulation	By means of optocouplers, 2000 V _{RMS} outputs to measuring inputs, 2000 V _{RMS} output to supply input. Insulation between the two outputs: 2000 V _{RMS}
	• one output remotely controlled by means of the serial port and one pulse output (kWh or kvarh)		
Pulse outputs			
Number of outputs	2		
Number of pulses	From 0.01 to 100 pulses programmable according to the selected CT and VT ratios		
Output type	Open collector (transistor NPN) V _{ON} 1.2 VDC / max. 100 mA V _{OFF} 30 VDC max.		
Pulse duration	220 ms (ON), ≥ 220 ms (OFF)		

Software functions

Password	Numeric code of max. 3 digits 2 protection levels of the programming data Password "0", no protection Password from 1 to 1000, all data are protected	Electrical range	Programmable within the whole measuring range.
1 st level 2 nd level		Filter	
		Filter operating range	0 to 99.9% of the input electrical scale.
		Filter coefficient	1 to 16
		Filter action	Alarm, analogue and serial output (fundamental variables: V, A, W and their derived ones).
System selection	Three-phase with neutral Three-phase without neutral		
Transformer ratio		Display	
CT	1 to 5000	System variables	Up to 4 variables per page Page 1: W-var-PF (cosφ) Page 2: W dmd - VA dmd - Hz Page 3: THD-V Page 4: THD-A Page 5: kWh total Page 6: kvarh total Page 7: kWh partial Page 8: kvarh partial Page 9: V _{L-N} Page 10: A Page 11a: A _{MAX} Page 11b: W dmd _{MAX} VA dmd _{MAX} Page 12: W Page 13: VA Page 14: var Page 15: PF (cosφ)
VT	1.0 to 199.9 and 200 to 1999 Note: The CT ratio* VT ratio must never exceed the value 5000. The current measuring inputs can manage CT's with a secondary of 1A and 5A (the accuracy always refer to 5A)	Single phase variables	
		System variables	
		Single phase variables	
Scaling factor		20(90) A 5(10) A	
Operating mode	Compression/expansion of the measuring range to be connected to the analogue output.		

Supply specifications

Self supplied version	400V _{L-L} -20% +15%, 50-60Hz 208V _{L-L} -20% +15% , 50-60Hz	48VAC -15 +10%, 50-60Hz 24VAC -15 +10%, 50-60Hz 18 to 60VDC 77 to 143VDC
Auxiliary power supply	230VAC -15 +10%, 50-60Hz 115VAC -15 +10%, 50-60Hz	
		Energy consumption
		≤ 7VA

General Specifications

Operating temperature	0 to +55°C (R.H. < 90% non-condensing 40°C)	Pulse voltage (1.2/50μs)	8kV (EN61000-4-5)
Storage temperature	-20 to +60°C (R.H. < 90% non-condensing 40°C)	Standards	
Installation category	Cat. III (IEC 664)	Safety	IEC664-1
Insulation	2000 V _{RMS} between all inputs / outputs to earth	Metrology	Energy measurements: EN61036, EN61268. DIN43864
Dielectric strength	4000 V _{RMS} for 1 minute	Pulse output	
Noise rejection		Approvals	CE
CMRR	100 dB, 48 to 62 Hz	Connections 5(10) A	Screw-type, 4 mm ²
EMC		Cable cross-section area	
Burst	4kV/level 4 (EN61000-4-4)	Connections 20(90) A	Screw-type, 6 mm ² / 35 mm ² 2 Nm / 6 Nm
Immunity to irradiated electromagnetic fields	10V/m 26-1000MHz (EN61000-4-3)	Housing	
Electrostatic discharges	15kV (EN61000-4-2) according to CISPR 14 and CISPR 22	Dimensions	162.5 x 90 x 63 mm
Radio frequency emissions		Material	ABS, NORYL, PC self-extinguishing: UL 94 V-0
		Mounting	DIN-rail and wall
		Degree of protection	Front: IP40 Connections: IP20
		Weight	800 g approx. (packing included)

Function description

Input and output scaling capability

Working examples of the analogue output (Y) versus the input variable (x) - (input/output scaling possibilities).

Figure A

The sign of measured quantity and output quantity remains the same. The output quantity is proportional to the measured quantity.

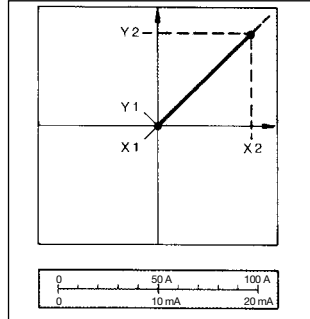

Figure B

The sign of measured quantity and output quantity remains the same. With the measured quantity being zero, the output quantity already has the value $Y_1 = 0.2 Y_2$. Live zero output.

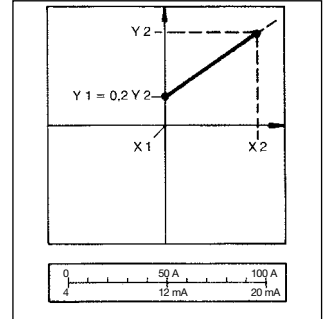
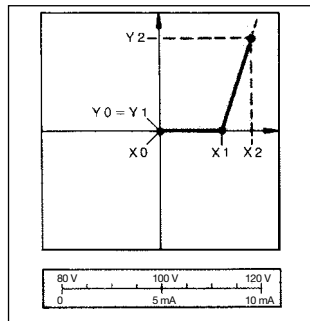

Figure C

The sign of measured quantity and output quantity remains the same. On the range $X_0...X_1$, the output quantity is zero. The range $X_1...X_2$ is delineated on the entire output range $Y_0=Y_1...Y_2$ and thus presented in strongly expanded form.



Mode of Operation

Waveform of the signals that can be measured

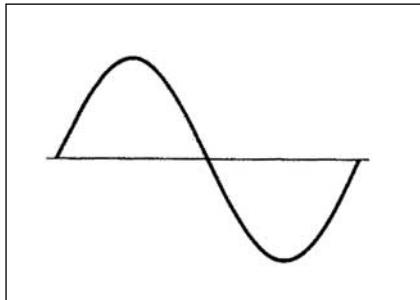

Figure D

Sine wave, undistorted

Fundamental content 100%
 Harmonic content 0%
 $A_{rms} = 1.1107 | \bar{A} |$

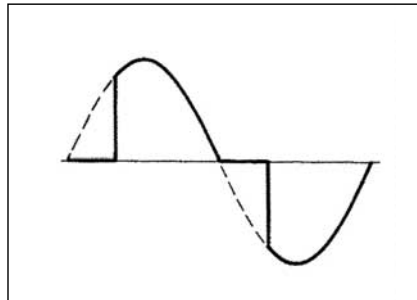

Figure E

Sine wave, indented

Fundamental content 10...100%
 Harmonic contents 0...90%
 Frequency spectrum: 3rd to the 16th harmonic
 Additional error: <1% rdg

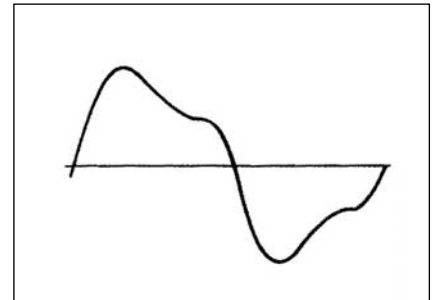

Figure F

Sine wave, distorted

Fundamental content 70...90%
 Harmonic content 10...30%
 Frequency spectrum: 3rd to the 16th harmonic
 Additional error: <0.5% rdg

Harmonic distortion analysis

Anaysis principle	FFT	THD (AL2), THD (AL3)
Harmonic measurement		THD %
Current	Up to the 7 th harmonic	The harmonic distortion can be measured in 3-wire or 4-wire systems.
Voltage	Up to the 7 th harmonic	
Type of harmonics	THD (VL1), THD (VL2), THD (VL3), THD (AL1)	



Display pages

Variables that can be displayed

No	1 st variable	2 nd variable	3 rd variable	4 th variable	Notes
1	W sys	PF sys	VAr sys		sys = system
2	W dmd	Hz	VA dmd		dmd = demand (integration time from 1 to 30 minutes)
3	V _{L1} THD	V _{L2} THD	V _{L3} THD		THD = tot. harmonic distortion
4	A _{L1} THD	A _{L2} THD	A _{L3} THD		THD = tot. harmonic distortion
5	kWh				total energy
6	kVArh				total energy
7	kWh				partial energy
8	kVArh				partial energy
9	V _{L1}	V _{L2}	V _{L3}	V _{L-L} sys	sys = system
10	A _{L1}	A _{L2}	A _{L3}	Err	Err = in case of negative power
11a	W dmd MAX	VA dmd MAX			Only version 1-5A, dmd = demand
11b	A _{L1} MAX	A _{L2} MAX	A _{L3} MAX		Only version 90A
12	W _{L1}	W _{L2}	W _{L3}	W sys	sys = system
13	VA _{L1}	VA _{L2}	VA _{L3}	VA sys	The system value remains always 0 if the neutral is not connected
14	VAr _{L1}	VAr _{L2}	VAr _{L3}	VAr sys	
15	PF _{L1}	PF _{L2}	PF _{L3}	PF sys	

Used calculation formulas

Phase variables

Instantaneous effective voltage

$$V_{IN} = \sqrt{\frac{1}{n} \cdot \sum_1^n (V_{IN})_i^2}$$

Instantaneous active power

$$W_1 = \frac{1}{n} \cdot \sum_1^n (V_{IN})_i \cdot (A_1)_i$$

Instantaneous power factor

$$\cos\phi_1 = \frac{W_1}{VA_1}$$

Instantaneous effective current

$$A_1 = \sqrt{\frac{1}{n} \cdot \sum_1^n (A_1)_i^2}$$

Instantaneous apparent power

$$VA_1 = V_{IN} \cdot A_1$$

Instantaneous reactive power

$$VAr_1 = \sqrt{(VA_1)^2 - (W_1)^2}$$

System variables

Equivalent system voltage

$$V_s = \frac{V_1 + V_2 + V_3}{3} \cdot \sqrt{3}$$

System reactive power

$$VAr_s = (VAr_1 + VAr_2 + VAr_3)$$

System active power

$$W_s = W_1 + W_2 + W_3$$

System apparent power

$$VA_s = \sqrt{W_s^2 + VAr_s^2}$$

System power factor

$$\cos\phi_s = \frac{W_s}{VA_s} \quad (\text{TPF})$$

Total harmonic distortion

$$THD_i = \frac{\sqrt{\sum_{n=2}^{\infty} T_{n,i}^2}}{T_{1,i}}$$

Note:

i = phase (L1, L2 or L3)

T = variable (V or I)

n = harmonic order

Consumption recording

$$kWh_i = \int_{t_1}^{t_2} P_i(t) dt \approx \Delta t \sum_{n_1}^{n_2} P_{n,i}$$

$$kVarh_i = \int_{t_1}^{t_2} Q_i(t) dt \approx \Delta t \sum_{n_1}^{n_2} Q_{n,i}$$

Note:

i = phase (L1, L2 or L3)

P = active power

Q = reactive power

t₁, t₂ = starting and ending time points of consumption recording

n = time unit

Δt = time interval of consumption recording

n₁, n₂ = starting and ending discrete time points of consumption recording

List of the of the variables that can be connected to the analogue and alarm output

N°	Variable	Notes	N°	Variable	Notes
1	V sys	sys = system	6	THD-V	Max. THD value among the three phases
2	W sys	sys = system	7	THD-A	Max. THD value among the three phases
3	var sys	sys = system	8	VA dmd	Power demand in the selected
4	VA sys	sys = system	9	W dmd	integration time
5	PF sys	sys = system	10	ASY	Phase asymmetry

Available models

Type	Inputs	Power supply	Ordering code
WM22-DIN AV9.3.X.	400V _{L-L} , 20(90)A	Self power supply	AF2100
WM22-DIN AV8.3.X.	208V _{L-L} , 20(90)A	Self power-supply	AF2101
WM22-DIN AV1.3.D.	400V _{L-L} , 20(90)A	230VAC, 50-60Hz	AF2102
WM22-DIN AV0.3.D.	208V _{L-L} , 20(90)A	230VAC, 50-60Hz	AF2103
WM22-DIN AV3.3.D.	660V _{L-L} , 20(90)A	230VAC, 50-60Hz	AF2104
WM22-DIN AV1.3.C.	400V _{L-L} , 20(90)A	115VAC, 50-60Hz	AF2105
WM22-DIN AV0.3.C.	208V _{L-L} , 20(90)A	115AC, 50-60Hz	AF2106
WM22-DIN AV3.3.C.	660V _{L-L} , 20(90)A	115VAC, 50-60Hz	AF2107
WM22-DIN AV1.3.B.	400V _{L-L} , 20(90)A	48VAC, 50-60Hz	AF2108
WM22-DIN AV0.3.B.	208V _{L-L} , 20(90)A	48VAC, 50-60Hz	AF2109
WM22-DIN AV3.3.B.	660V _{L-L} , 20(90)A	48VAC, 50-60Hz	AF2110
WM22-DIN AV1.3.A.	400V _{L-L} , 20(90)A	24VAC, 50-60Hz	AF2111
WM22-DIN AV0.3.A.	208V _{L-L} , 20(90)A	24VAC, 50-60Hz	AF2112
WM22-DIN AV3.3.A.	660V _{L-L} , 20(90)A	24VAC, 50-60Hz	AF2113
WM22-DIN AV5.3.D.	400V _{L-L} , 5(10)A	230VAC, 50-60Hz	AF2114
WM22-DIN AV4.3.D.	208V _{L-L} , 5(10)A	230VAC, 50-60Hz	AF2115
WM22-DIN AV7.3.D.	660V _{L-L} , 5(10)A	230VAC, 50-60Hz	AF2116
WM22-DIN AV5.3.C.	400V _{L-L} , 5(10)A	115VAC, 50-60Hz	AF2117
WM22-DIN AV4.3.C.	208V _{L-L} , 5(10)A	115VAC, 50-60Hz	AF2118
WM22-DIN AV7.3.C.	660V _{L-L} , 5(10)A	115VAC, 50-60Hz	AF2119
WM22-DIN AV5.3.B.	400V _{L-L} , 5(10)A	48VAC, 50-60Hz	AF2120
WM22-DIN AV4.3.B.	208V _{L-L} , 5(10)A	48VAC, 50-60Hz	AF2121
WM22-DIN AV7.3.B.	660V _{L-L} , 5(10)A	48VAC, 50-60Hz	AF2122
WM22-DIN AV5.3.A.	400V _{L-L} , 5(10)A	24VAC, 50-60Hz	AF2123
WM22-DIN AV4.3.A.	208V _{L-L} , 5(10)A	24VAC, 50-60Hz	AF2124
WM22-DIN AV7.3.A.	660V _{L-L} , 5(10)A	24VAC, 50-60Hz	AF2125
WM22-DIN AV6.3.D.	100V _{L-L} , 5(10)A	230VAC, 50-60Hz	AF2126
WM22-DIN AV6.3.C.	100V _{L-L} , 5(10)A	115VAC, 50-60Hz	AF2127
WM22-DIN AV6.3.B.	100V _{L-L} , 5(10)A	48VAC, 50-60Hz	AF2128
WM22-DIN AV6.3.A.	100V _{L-L} , 5(10)A	24VAC, 50-60Hz	AF2129
WM22-DIN AV1.3.4 / [5]	400V _{L-L} , 20(90)A	18-60VDC [77-143VDC]	AF2130 [AF2137]
WM22-DIN AV0.3.4 / [5]	208V _{L-L} , 20(90)A	18-60VDC [77-143VDC]	AF2131 [AF2138]
WM22-DIN AV3.3.4 / [5]	660V _{L-L} , 20(90)A	18-60VDC [77-143VDC]	AF2132 [AF2139]
WM22-DIN AV5.3.4 / [5]	400V _{L-L} , 5(10)A	18-60VDC [77-143VDC]	AF2133 [AF2140]
WM22-DIN AV4.3.4 / [5]	208V _{L-L} , 5(10)A	18-60VDC [77-143VDC]	AF2134 [AF2141]
WM22-DIN AV7.3.4 / [5]	660V _{L-L} , 5(10)A	18-60VDC [77-143VDC]	AF2135 [AF2142]
WM22-DIN AV6.3.4 / [5]	100V _{L-L} , 5(10)A	18-60VDC [77-143VDC]	AF2136 [AF2143]

Available modules

Type	Channels	Code	Type	Channels	Code
Open collector output	2	AO2900	0-10VDC Analogue Output	1	AO2921
0-20mADC analogue output	1	AO2920	RS485 Serial Output	1	AR2950
Relay + open c. output	2	AO2910			

Possible module combinations

Power supply	Self p.s.		Auxiliary p.s.		Power supply	Self p.s.		Auxiliary p.s.	
	Slot A	Slot B	Slot A	Slot B		Slot A	Slot B	Slot A	Slot B
Basic unit					Basic unit				
Open collector output	●		●		Analogue output				●
Relay + open c. output	●		●		RS485 Serial Output				●



Wiring diagrams

20(90)A model: three-phase unbalanced load

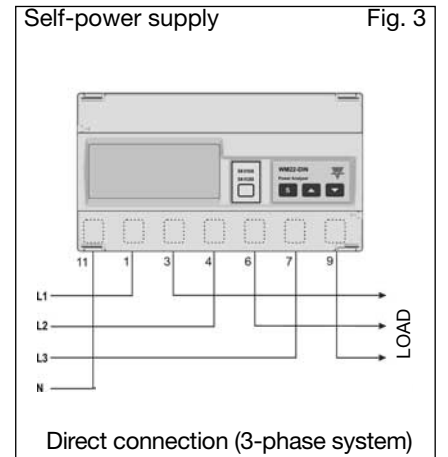
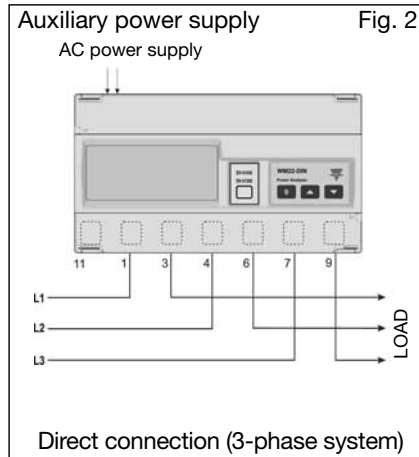
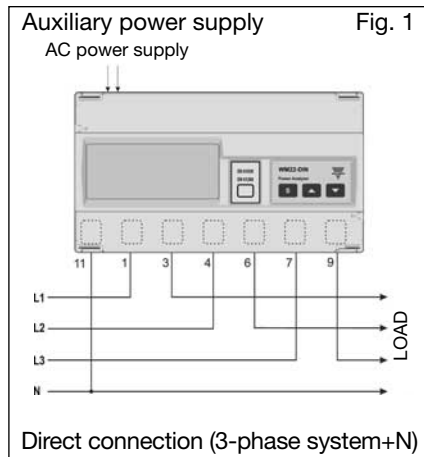

20(90)A model: three-phase unbalanced load

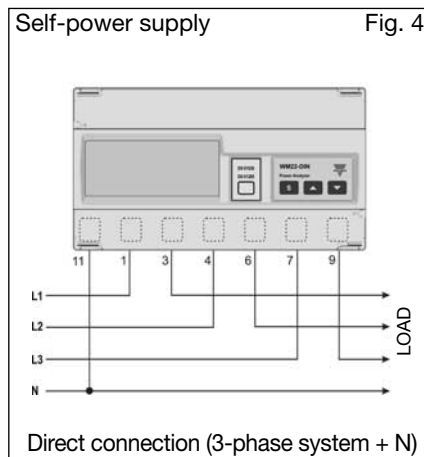

5(10)A model: three-phase unbalanced load

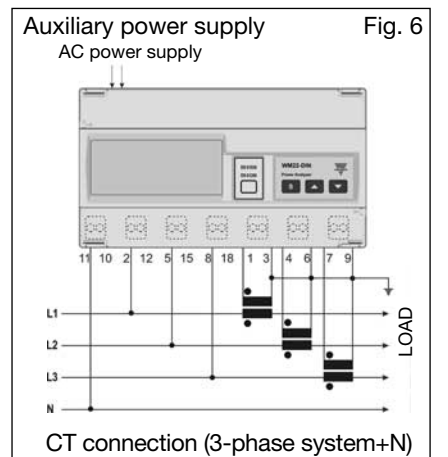
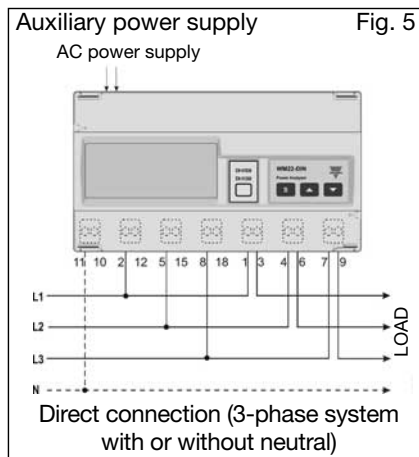

5(10)A model: three-phase unbalanced load

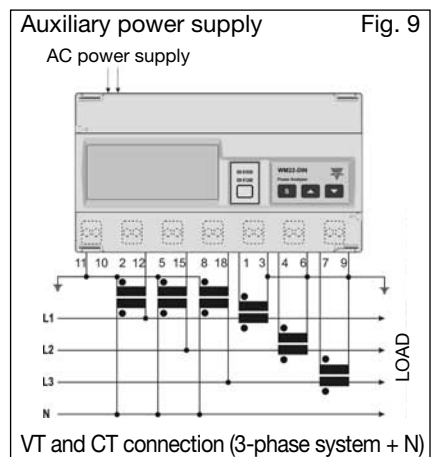
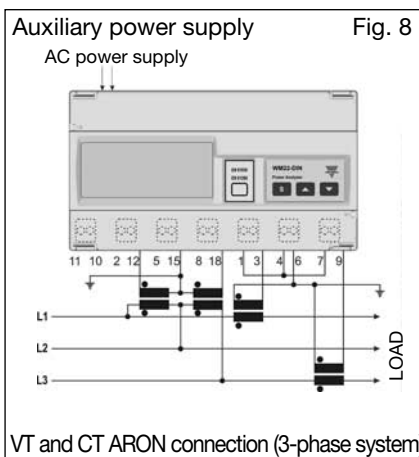
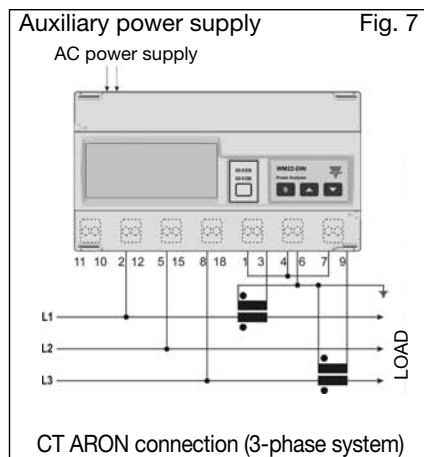

Wiring diagrams (optional modules)

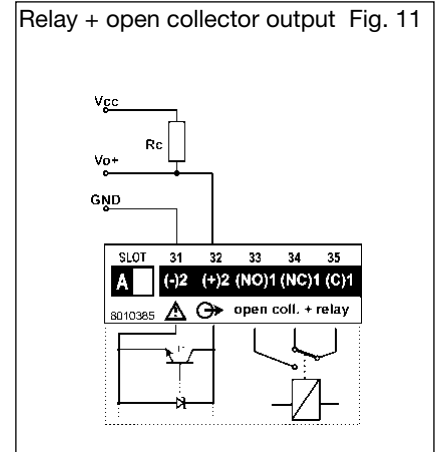
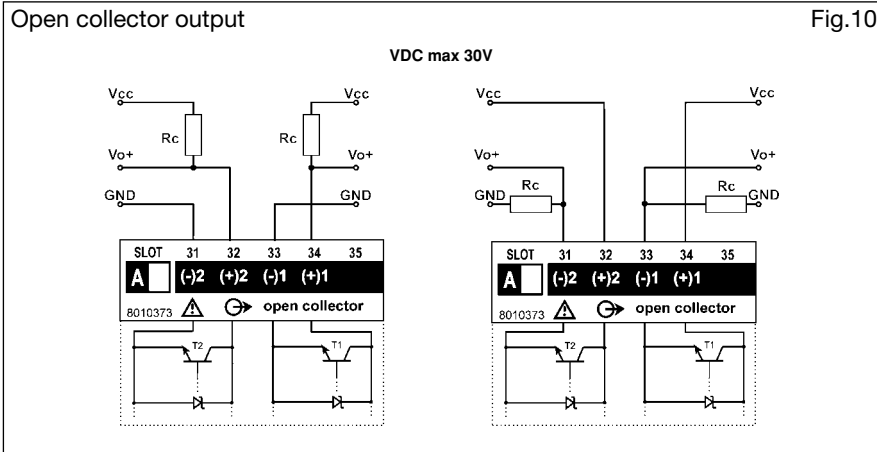

Only open collector outputs: the grounds of the outputs are separated, and therefore it's possible to carry out, for the same module, two different connections. The load resistance (R_c) must be designed so that the closed contact current is lower than 100mA; the VDC voltage must be lower than or equal to 30V. VDC: power supply voltage output. V_{o+} : positive output contact (open collector transistor). GND: ground output contact (open collector transistor).

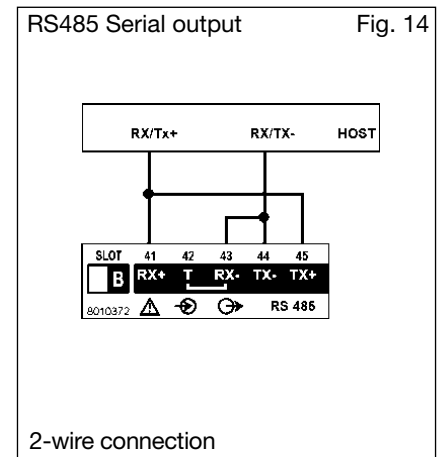
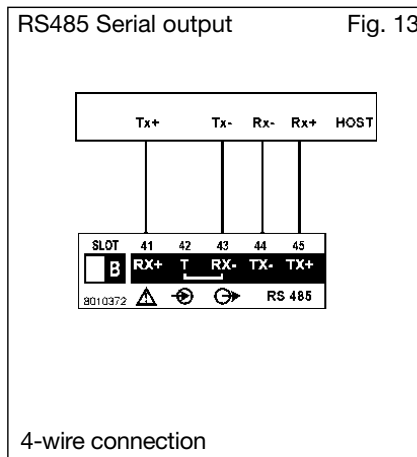
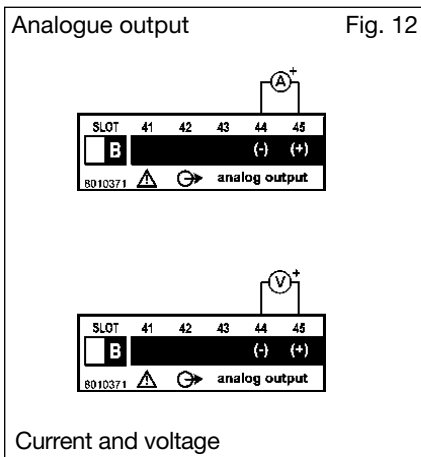

Front panel description

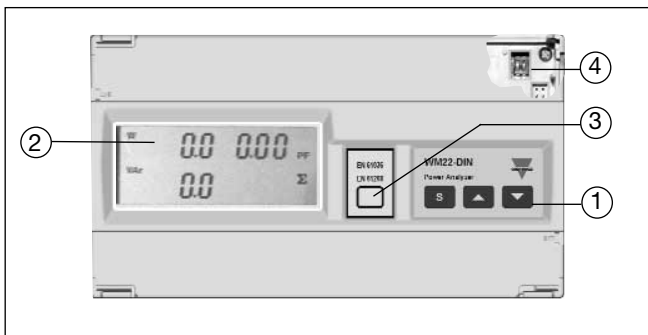

1. Key-pad

To program configuration parameters and to display variables.



S-key to enter programming and confirm selections;



Keys for:

- value programming;
- function selection;
- displaying the measuring pages.

2. Display

LCD with alphanumeric indications to:

- display configuration parameters;
- display all the measured variables.

3. Removable label

Label to write the instrument ID number.

4. Hidden dip-switch

Enable/ disable the access to the programming procedure.



Dimensions and panel cut-out

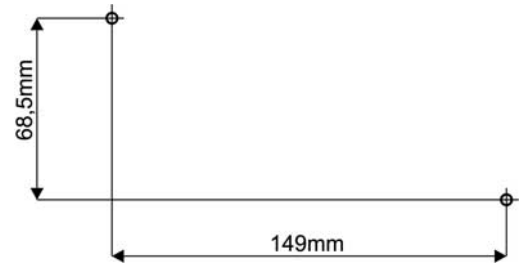
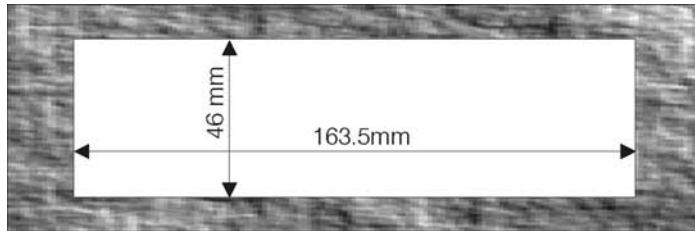
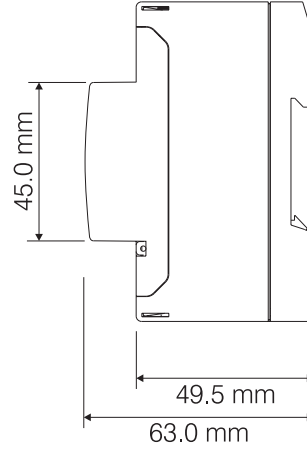
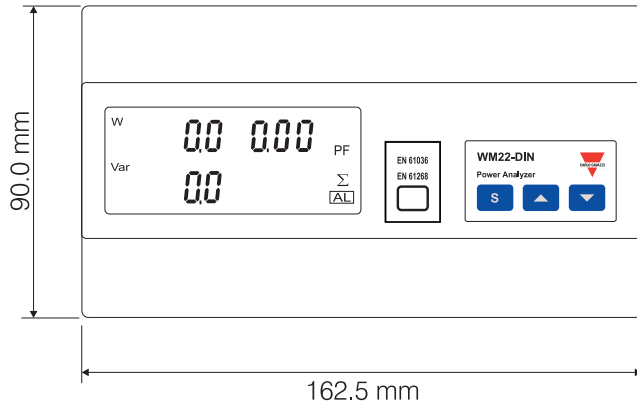

Terminal boards

Analogue output module

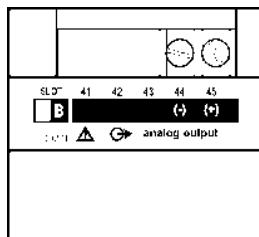

AO 2920: 0-20 mA
AO 2921: 0-10 V

Dual output open collector module

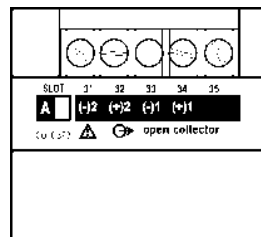

AO 2900

Relay output module + open collector output

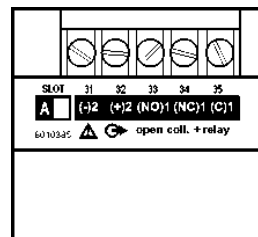

AO 2910

RS485 serial output module

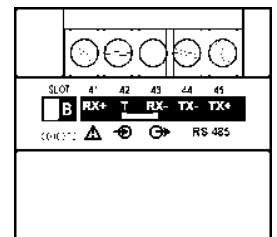

AR 2950