

Energy Management

Three-phase energy meter with output modules

Type EM4-DIN

CARLO GAVAZZI



- Degree of protection (front): IP 40
- Front dimensions: 9 DIN modules
- RS 422/485 Serial port by means of optional module
- Dual pulse output by means of optional module
- Alarm output (kW dmd) by means of optional module
- Digital inputs for the management of the time periods and of the H₂O and GAS meters

- Class 1 (active energy)
- Class 2 (reactive energy)
- Three-phase multi-function energy meter
- Back-lighted LCD display
- 3¹/₂ DGT instantaneous variables read-out
- 8 DGT + 7¹/₂ DGT energy read-out
- Measurements of system and phase variables: W, Wdmd
- Measurements of total energies: kWh, kvarh
- Measurements of partial energies: kWh, kvarh
- Energy measurements according to EN61036 and EN61268
- Energy measurements by time periods (t1-t2-t3-t4) selectable by input contacts
- Measurements of m³ H₂O and m³ GAS by means of input contacts

- TRMS measurements of distorted wave forms (voltages/currents)
- Two basic models: direct connection 20(90)AAC, CT 5(10)AAC and VT connection
- Self power supply (available for some models only) or auxiliary power supply: 24V, 48V, 115V, 230V, 50-60Hz; 18 to 60VDC, 77 to 143VDC

Product description

Three-phase energy meter with built-in configuration key-pad; particularly indicated for the metering and the management of the energy in addition to the metering and the management of the signals coming from the water and gas meters. Housing for DIN-rail or wall-mounting, IP40 (front) protection degree. Completely sealable housing. In case of direct connection up to 90A, the measuring

input terminals are suitable for cables with a cross-section area from 6 to 35 mm². The special design of the instrument's housing allows to add at any time the interface modules, even when the instrument is already installed. The following modules are available:

- for all versions: pulse output;
- only for the versions with auxiliary power supply: digital inputs, RS485 serial port.

How to order **EM4-DIN AV5 3 X X XX**



Type selection

Range Code	Power supply	Slot A (retransmission)	Slot A (retransmission) cont.
Auxiliary Power Supply:			
AV0: 208V _{L-L} /20(90)AAC [3]	For all versions A: 24VAC -15+10%, 50-60Hz B: 48VAC -15+10%, 50-60Hz C: 115VAC -15+10%, 50-60Hz D: 230VAC -15+10%, 50-60Hz 4: 18 to 60VDC 5: 77 to 143VDC Only for AV8 and AV9 versions X: Self Power Supply 400V _{L-L} -20+15%, 50-60Hz 208V _{L-L} -20+15%, 50-60Hz	X: None O: AO2900 module Dual open collector output. Three operating modes: <ul style="list-style-type: none">• two pulse outputs (kWh and kvarh);• one alarm output (kW dmd) and one pulse output (kWh or kvarh)• one output remotely controlled by a serial port and one pulse output (kWh or kvarh)	R: AO2910 module. One relay output + one open collector output. Operation modes like module AO2900
AV1: 400V _{L-L} /20(90)AAC [1]			
AV3: 660V _{L-L} /20(90)AAC [2]			
AV4: 208V _{L-L} /5(10)AAC [3]			
AV5: 400V _{L-L} /5(10)AAC [1]			
AV6: 100V _{L-L} /5(10)AAC [3]			
AV7: 660V _{L-L} /5(10)AAC [2]			
Self Power Supply:			
AV8: 208V _{L-L} /20(90)AAC [1]	4: 18 to 60VDC 5: 77 to 143VDC	D: AQ2940 module Two digital inputs for the management of water and gas meters	Slot B (retransmission) Only with A-B-C-D-4 power supply XX: None S0: AR2950 module RS422/485 serial port
AV9: 400V _{L-L} /20(90)AAC [1]			
System			
3: Three-phase, balanced and unbalanced load with or without neutral			

[1] Un: -20+15% [2] Un: -30+15% [3] Un: -20+20%

Specifications are subject to change without notice

Input specifications

Number of inputs		Temperature drift	≤ 200ppm/°C
Current	3	Sampling rate	1000 samplings/s @ 50Hz
Voltage	4	Display	
Accuracy (display, RS485)	lb: 5A, I _{max} : 10A lb: 20A, I _{max} : 90A Un: see "Range code" on previous page	Type	Back-lighted LCD
Current	from 0.003lb to 0.2lb: ±(0.5%RDG +3DGT) from 0.2lb to I _{max} : ±(0.5%RDG +1DGT)	Instantan. variables read-out	3½ DGT
Voltage	in the range Un: ±(0,5% RDG + 1DGT)	Energies	Total: 8 DGT + 7½ DGT; Partial: 8 DGT + 7½ DGT;
Frequency	±0.1% RDG (50 to 60 Hz)	Max. and Min. indication	Max. 1999 (99999999), Min. 0
Active power (@ 25°C ± 5°C, R.H. ≤ 90%)	±(1% RDG +1DGT). PF 1, 0.1lb to I _{max} , in the Un range; PF 0.5L, PF 0.8C, 0.2lb to I _{max} , in the Un range	Measurements	Power, energy. TRMS measurements of distorted wave forms. Direct
Energies (@ 25°C ± 5°C, R.H. ≤ 90%)	Class 1 acc. to EN61036 Class 2 acc. to EN61268 lb: 5A, I _{max} : 10A 0.1lb: 500mA, Start up current: 20mA Un: see table "range code" lb: 20A, I _{max} : 90A 0.1lb: 2A, Start up current: 80mA Un: see table "range code"	Coupling type	
Additional errors	Acc. to EN61036, EN61268	Crest factor	
Wave form	< 1% (3 rd harmonic: 10%)	lb 5A	≤ 3 (15A max. peak)
Voltage asymmetry	< 0.5% (referred to Un)	lb 20A	≤ 6 (127A max. peak)
Magnetic induction	0 (up to 0.5 mT)	Current overload	
HF Electromagnetic fields	< 1%	5(10) A, for 10ms	300A max, @ 50Hz
Operation of accessories	0	5(10) A, for 500ms	200A max, @ 50Hz
		5(10) A, permanent	10A, @ 50Hz
		20(90) A, for 10ms	2700A max, @ 50Hz
		20(90) A, permanent	90A, @ 50Hz
		Voltage overload	
		Permanent	1.2 Un
		For 1s	2 Un
		Input impedance	
		400V _{L-L} (AV1-AV5-AV9)	> 720KΩ
		208V _{L-L} (AV0-AV4-AV8)	> 720KΩ
		660V _{L-L} (AV3-AV7)	> 1.97MΩ
		100V _{L-L} (AV6)	> 400KΩ
		5(10) A (AV4-AV5-AV6-AV7)	< 0.3VA
		20(90) A (AV0-AV1-AV3-AV8-AV9)	< 4VA
		Frequency	50 to 60 Hz

Interface module specifications

RS422/RS485 (on request)	AR2950 module	2000 V _{RMS} output to supply input
Type	Multidrop bidirectional (static and dynamic variables)	
Connections	2 or 4 wires, max. distance 1200m, termination directly on the module	Digital outputs (on request)
Addresses	255, selectable by key-pad	AO2900 module
Protocol	MODBUS/JBUS	To be used as energy retransmission, water and gas, remote static outputs and alarm. Three working modes are selectable:
Data (bidirectional)		• two pulse outputs (kWh and kvarh);
Dynamic (reading only)	Phase and system variables: see table "Display pages"	• one alarm output (kW dmd) and one pulse output (kWh or kvarh);
Static (writing only)	All the programming data, reset of energy, activation of static output.	• one output remotely controlled by means of the serial port and one pulse output (kWh or kvarh)
Data format	Stored energy (EEPROM) max. 99.999.999 kWh/kvarh	
Baud-rate	1 start bit, 8 data bit, no parity, 1 stop bit	Pulse outputs
Insulation	9600 bit/s	Number of outputs
	By means of optocouplers, 2000 V _{RMS} output to measuring inputs	Number of pulses
		Output type
		2
		From 0.01 to 100 pulses programmable according to the selected CT and VT ratios
		Open collector (NPN transistor)

Interface module specifications (cont.)

Pulse duration	V_{ON} 1.2 VDC / max. 100 mA V_{OFF} 30 VDC max. 220 ms (ON), \geq 220 ms (OFF) According to DIN43864	Digital inputs (on request)	AQ2940 module Four working modes are selectable: <ul style="list-style-type: none"> total and partial energy meters (kWh and kvarh) without the use of digital inputs total and partial energy meters (kWh and kvarh) managed by time periods (t_1-t_2-t_3-t_4); total energy meters (kWh, kvarh) and total "day-time/night" GAS meter; total energy meters (kWh, kvarh), GAS and WATER meters;
	Alarm output		
Insulation	By means of optocouplers, 2000 V_{RMS} outputs to measuring inputs, 2000 V_{RMS} output to supply input. Insulation between the two outputs: functional relay + open collector output . Working mode like AO2900	Number of inputs: 2 Input frequency: 20Hz max. Duty cycle: 50% Prescaler adjustment: from 0,1 to 100,0 m ³ / pulse Contact measur. voltage: 12V < +Aux < 24VDC Logic status: OFF < 2V, ON > 10V Contact measur. current: 15mA max Input impedance: 1k Ω Contact resistance: \leq 1k Ω , close contact \geq 100k Ω , open contact	By means of optocouplers, 2000 V_{RMS} digital inputs to measuring inputs, 2000 V_{RMS} digital inputs to supply input.
AO2910 module	Insulation between the two outputs: functional relay + open collector output . Working mode like AO2900	Contact resistance: \leq 1k Ω , close contact \geq 100k Ω , open contact	
Pulse output	like AO2900	Insulation	
Alarm output	like AO2900		
Insulation	2000 V_{RMS} outputs to measuring inputs, 2000 V_{RMS} output to supply input. Insulation between the two outputs: 2000 V_{RMS}		

Software functions

Password	Numeric code of max. 3 digits 2 protection levels of the programming data Password "0", no protection 1 st level: Password from 1 to 1000, 2 nd level: all data are protected	Display Variables	to 5A) Up to 4 variables per page Page 1: kWh-kvarh Page 2a: k Wh (t_1 - t_2 - t_3 - t_4) k varh (t_1 - t_2 - t_3 - t_4) Page 2b: GAS m ³ day-time tariff, GAS m ³ night tariff Page 2c: H ₂ O m ³ , GAS m ³ Page 3: W_{L1} Page 4: W_{L2} Page 5: W_{L3} Page 6: W_{dmd} Phase sequence, serial communication status, wrong connection of current measuring inputs.
Transformer ratio	1 to 5000 CT: 1.0 to 199.9 and 200 to 1999 VT: Note: The CT ratio * VT ratio must never exceed the value 5000. The current measuring inputs can manage CT's with a secondary of 1A and 5A (accuracy always refers	Errors	

Supply specifications

Self supplied version	400V _{L-L} -20% +15%, 50-60Hz 208V _{L-L} -20% +15% , 50-60Hz	115V AC -15 +10%, 50-60Hz 48VAC; -15 +10%, 50-60Hz 24VAC; -15 +10%, 50-60Hz 18 to 60VDC; 77 to 143VDC
Auxiliary power supply	230V AC -15 +10%, 50-60Hz	Energy consumption \leq 7VA

General Specifications

Operating temperature	0 to +55°C (R.H. < 90% non-condensing 40°C)	Pulse voltage (1.2/50µs)	8kV (EN61000-4-5)
Storage temperature	-20 to +60°C (R.H. < 90% non-condensing 40°C)	Standards	IEC664-1 Energy measurements: EN61036, EN61268. DIN43864
Installation category	Cat. III (IEC 664)	Safety Metrology	
Insulation	2000 V _{RMS} between all inputs / outputs to earth	Pulse output	
Dielectric strength	4000 V _{RMS} for 1 minute	Approvals	CE
Noise rejection CMRR	100 dB, 48 to 62 Hz	Connections 5(10) A	Screw-type, 4 mm ²
EMC		Connections 20(90) A	Screw-type, 6 mm ² / 35 mm ² Min./Max. screws tightening torque 2 Nm / 6 Nm (90A inputs)
Burst	4kV/level 4 (EN61000-4-4)	Housing	
Immunity to irradiated electromagnetic fields	10V/m 26-1000MHz (EN61000-4-3)	Dimensions	162.5 x 90 x 63 mm
Electrostatic discharges	15kV (EN61000-4-2)	Material	ABS, NORYL, PC self-extinguishing: UL 94 V-0
Radio frequency emissions	according to CISPR 14 and CISPR 22	Mounting	DIN-rail and wall
		Degree of protection	Front: IP40 Connections: IP20
		Weight	800 g approx. (packing included)

Display pages

Variables that can be displayed

No	1 st variable	2 nd variable	Notes
1	kWh	kvarh	
2a	kWh (t ₁ or t ₁ -t ₂ -t ₃ -t ₄)	kvarh (t ₁ or t ₁ -t ₂ -t ₃ -t ₄)	Depending on the type of selection you have chosen.
2b	Day-time GAS m ₃	Night GAS m ₃	For the energy it is possible to choose the following operating mode: t ₁ partial meters or t ₁ -t ₂ -t ₃ -t ₄ multitariff selection
2c	H ₂ O m ₃	GAS m ₃	
3	W _{L1}		
4	W _{L2}		
5	W _{L3}		
6	W _{dmd}		dmd = demand (integration time selectable from 1 to 30 min.)
7	Display of the serial communication status, phase sequence, wrong connection of current measuring inputs		

Used calculation formulas

Phase variables

Instantaneous effective voltage

$$V_{IN} = \sqrt{\frac{1}{n} \cdot \sum_1^n (V_{IN})_i^2}$$

Instantaneous active power

$$W_1 = \frac{1}{n} \cdot \sum_1^n (V_{IN})_i \cdot (A_1)_i$$

Instantaneous power factor

$$\cos\phi_1 = \frac{W_1}{VA_1}$$

Instantaneous effective current

$$A_1 = \sqrt{\frac{1}{n} \cdot \sum_1^n (A_1)_i^2}$$

Instantaneous apparent power

$$VA_1 = V_{IN} \cdot A_1$$

Instantaneous reactive power

$$VAR_1 = \sqrt{(VA_1)^2 - (W_1)^2}$$

Note: RS422/RS485 "dynamic data". The variables transmitted are the ones listed in the table above and those mentioned in the "Display pages" of WM22-DIN data sheet except for: THD_A, THD_V, A max, W_{dmd}max, and VA_{dmd} max.

System variables

Equivalent system voltage

$$V_2 = \frac{V_1 + V_2 + V_3}{3} \cdot \sqrt{3}$$

System reactive power

$$VAR_2 = (VAR_1 + VAR_2 + VAR_3)$$

System active power

$$W_2 = W_1 + W_2 + W_3$$

System apparent power

$$VA_2 = \sqrt{W_2^2 + VAR_2^2}$$

System power factor

$$\cos\phi_2 = \frac{W_2}{VA_2} \quad (\text{TPF})$$

Consumption recording

$$kWh_i = \int_{t_1}^{t_2} P_i(t) dt \approx \Delta t \sum_{n_1}^{n_2} P_{a,i}$$

$$kVarh_i = \int_{t_1}^{t_2} Q_i(t) dt \approx \Delta t \sum_{n_1}^{n_2} Q_{a,i}$$

Note:

i = phase (L1, L2 or L3)

P = active power

Q = reactive power

t₁, t₂ = starting and ending time points of consumption recording

n = time unit

Δt = time interval of consumption recording

n₁, n₂ = starting and ending discrete time points of consumption recording

Available models

Type	Inputs	Power supply	Ordering code
EM4-DIN AV9.3.X.	400V _{L-L} , 20(90)A	Self power supply	AG2200
EM4-DIN AV8.3.X.	208V _{L-L} , 20(90)A	Self power supply	AG2201
EM4-DIN AV1.3.D.	400V _{L-L} , 20(90)A	230VAC, 50-60Hz	AG2202
EM4-DIN AV0.3.D.	208V _{L-L} , 20(90)A	230VAC, 50-60Hz	AG2203
EM4-DIN AV3.3.D.	660V _{L-L} , 20(90)A	230VAC, 50-60Hz	AG2204
EM4-DIN AV1.3.C.	400V _{L-L} , 20(90)A	115VAC, 50-60Hz	AG2205
EM4-DIN AV0.3.C.	208V _{L-L} , 20(90)A	115VAC, 50-60Hz	AG2206
EM4-DIN AV3.3.C.	660V _{L-L} , 20(90)A	115VAC, 50-60Hz	AG2207
EM4-DIN AV1.3.B.	400V _{L-L} , 20(90)A	48VAC, 50-60Hz	AG2208
EM4-DIN AV0.3.B.	208V _{L-L} , 20(90)A	48VAC, 50-60Hz	AG2209
EM4-DIN AV3.3.B.	660V _{L-L} , 20(90)A	48VAC, 50-60Hz	AG2210
EM4-DIN AV1.3.A.	400V _{L-L} , 20(90)A	24VAC, 50-60Hz	AG2211
EM4-DIN AV0.3.A.	208V _{L-L} , 20(90)A	24VAC, 50-60Hz	AG2212
EM4-DIN AV3.3.A.	660V _{L-L} , 20(90)A	24VAC, 50-60Hz	AG2213
EM4-DIN AV5.3.D.	400V _{L-L} , 5(10)A	230VAC, 50-60Hz	AG2214
EM4-DIN AV4.3.D.	208V _{L-L} , 5(10)A	230VAC, 50-60Hz	AG2215
EM4-DIN AV7.3.D.	660V _{L-L} , 5(10)A	230VAC, 50-60Hz	AG2216
EM4-DIN AV5.3.C.	400V _{L-L} , 5(10)A	115VAC, 50-60Hz	AG2217
EM4-DIN AV4.3.C.	208V _{L-L} , 5(10)A	115VAC, 50-60Hz	AG2218
EM4-DIN AV7.3.C.	660V _{L-L} , 5(10)A	115VAC, 50-60Hz	AG2219
EM4-DIN AV5.3.B.	400V _{L-L} , 5(10)A	48VAC, 50-60Hz	AG2220
EM4-DIN AV4.3.B.	208V _{L-L} , 5(10)A	48VAC, 50-60Hz	AG2221
EM4-DIN AV7.3.B.	660V _{L-L} , 5(10)A	48VAC, 50-60Hz	AG2222
EM4-DIN AV5.3.A.	400V _{L-L} , 5(10)A	24VAC, 50-60Hz	AG2223
EM4-DIN AV4.3.A.	208V _{L-L} , 5(10)A	24VAC, 50-60Hz	AG2224
EM4-DIN AV7.3.A.	660V _{L-L} , 5(10)A	24VAC, 50-60Hz	AG2225
EM4-DIN AV6.3.D.	100V _{L-L} , 5(10)A	230VAC, 50-60Hz	AG2226
EM4-DIN AV6.3.C.	100V _{L-L} , 5(10)A	115VAC, 50-60Hz	AG2227
EM4-DIN AV6.3.B.	100V _{L-L} , 5(10)A	48VAC, 50-60Hz	AG2228
EM4-DIN AV6.3.A.	100V _{L-L} , 5(10)A	24VAC, 50-60Hz	AG2229
EM4-DIN AV1.3.4 / [5]	400V _{L-L} , 20(90)A	18-60VDC [77-143VDC]	AG2230 [AG2237]
EM4-DIN AV0.3.4 / [5]	208V _{L-L} , 20(90)A	18-60VDC [77-143VDC]	AG2231 [AG2238]
EM4-DIN AV3.3.4 / [5]	660V _{L-L} , 20(90)A	18-60VDC [77-143VDC]	AG2232 [AG2239]
EM4-DIN AV5.3.4 / [5]	400V _{L-L} , 5(10)A	18-60VDC [77-143VDC]	AG2233 [AG2240]
EM4-DIN AV4.3.4 / [5]	208V _{L-L} , 5(10)A	18-60VDC [77-143VDC]	AG2234 [AG2241]
EM4-DIN AV7.3.4 / [5]	660V _{L-L} , 5(10)A	18-60VDC [77-143VDC]	AG2235 [AG2242]
EM4-DIN AV6.3.4 / [5]	100V _{L-L} , 5(10)A	18-60VDC [77-143VDC]	AG2236 [AG2243]

Available modules

Type	Channels	Code	Type	Channels	Code
Open collector output	2	AO2900	Digital inputs	2	AQ2940
Relay + open coll. output	2	AO2910	RS485 Serial Output	1	AR2950

Possible module combinations

Power supply	Self p.s.		Auxiliary p.s.		Power supply	Self p.s.		Auxiliary p.s.	
	Slot A	Slot B	Slot A	Slot B		Slot A	Slot B	Slot A	Slot B
Basic unit					Basic unit				
Open collector output	●		●		Digital inputs			●	
Relay + open coll. output	●		●		RS485 Serial Output				●

Wiring diagrams

20(90)A model: three-phase unbalanced load

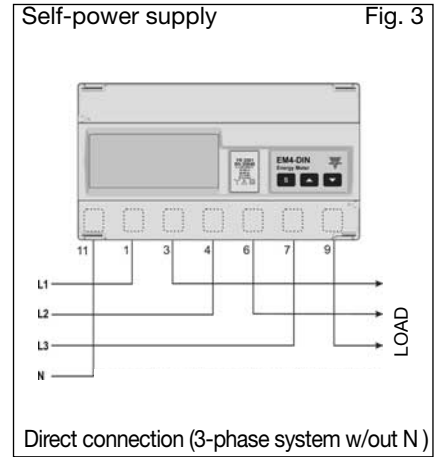
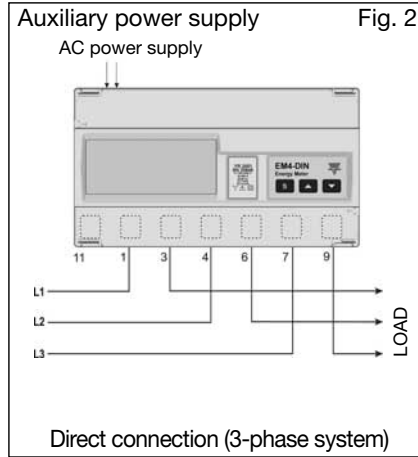
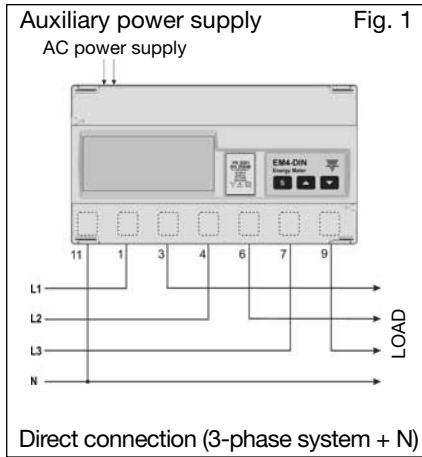

20(90)A model: three-phase unbalanced load

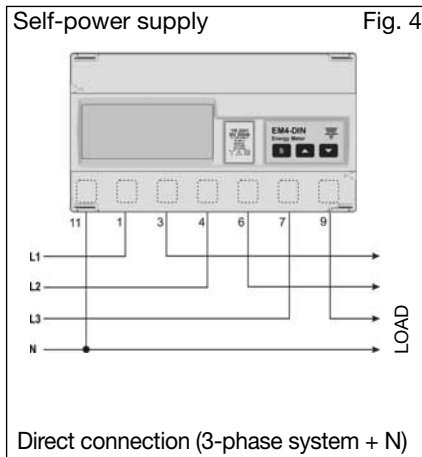

5(10)A model: three-phase unbalanced load

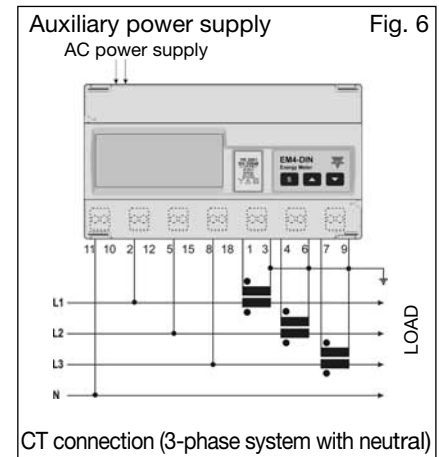
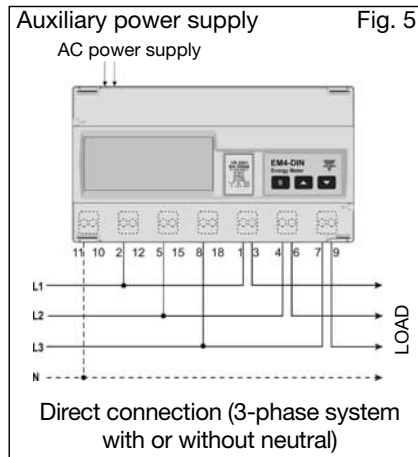

5(10)A model: three-phase unbalanced load

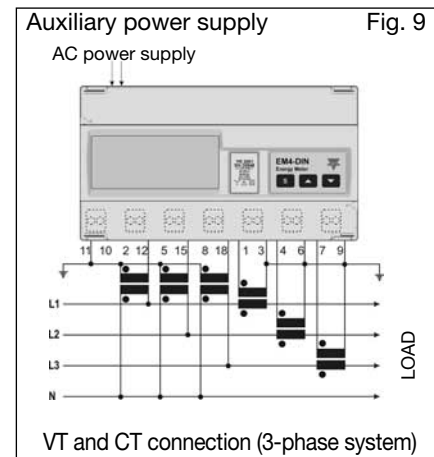
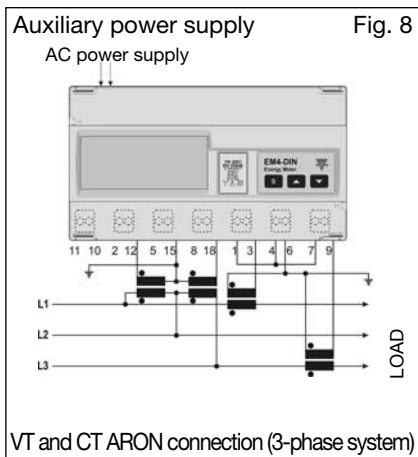
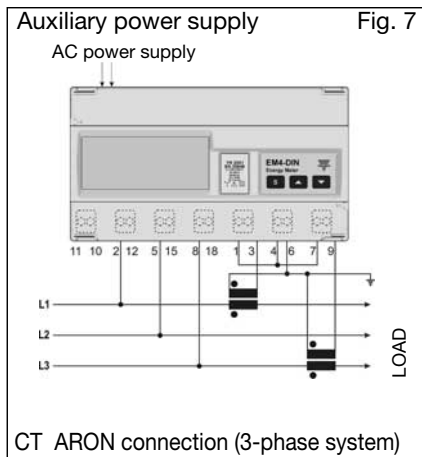

Wiring diagrams (optional modules)

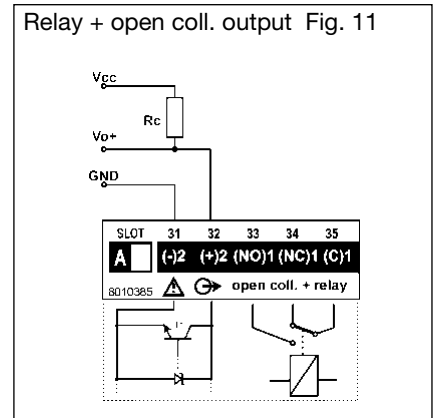
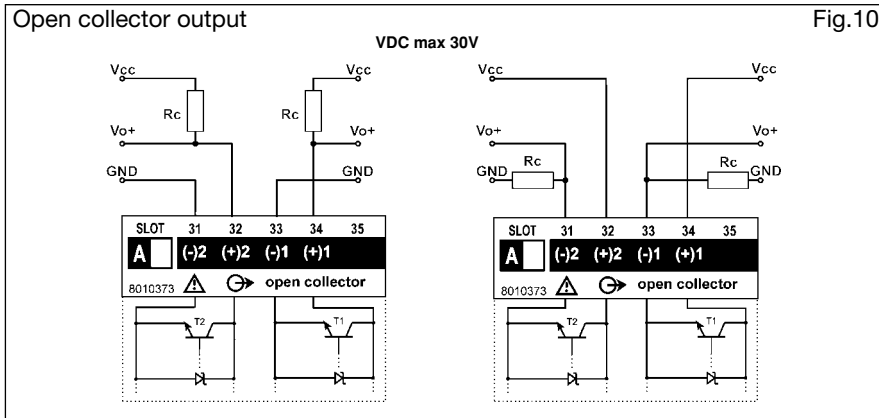

Only open collector outputs: the grounds of the outputs are separated, and therefore it's possible to carry out, for the same module, two different connections. The load resistance (Rc) must be designed so that the closed contact current is lower than 100mA; the VDC voltage must be lower than or equal to 30V. VDC: power supply voltage output. Vo+: positive output contact (open collector transistor). GND: ground output contact (open collector transistor).

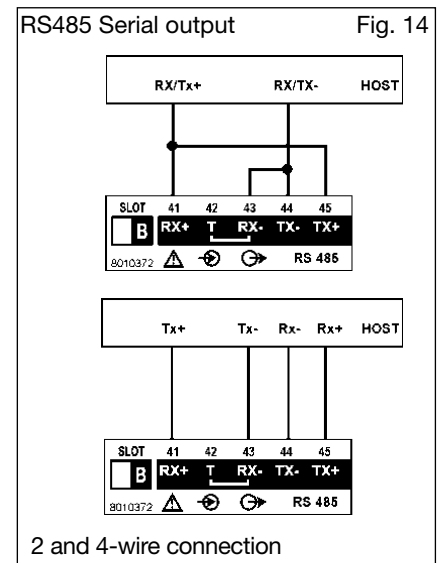
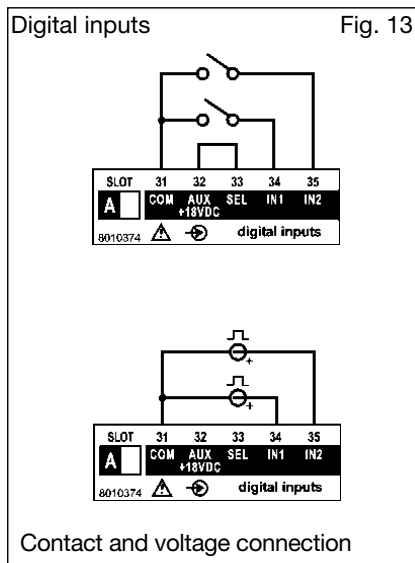
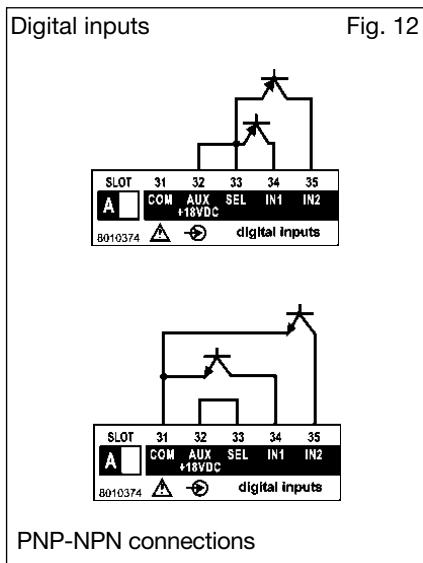

Accuracy

Accuracy (RDG) depending on the current

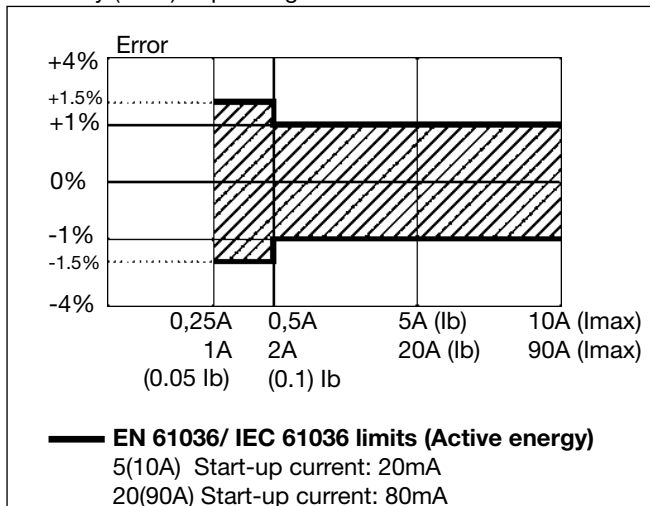

Accuracy (RDG) depending on the current

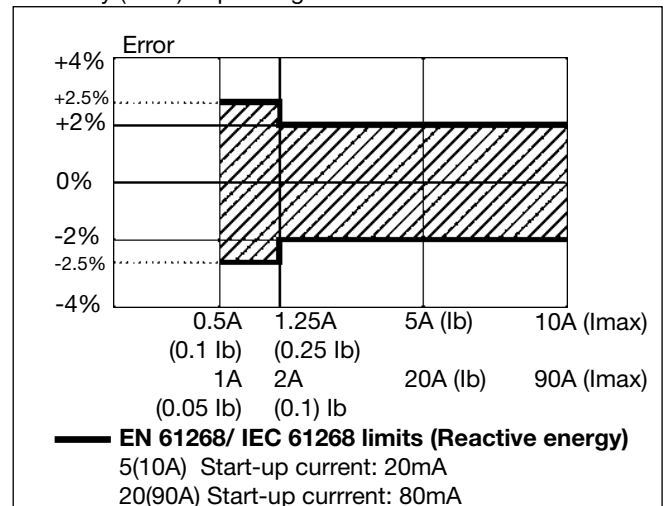

Front panel description

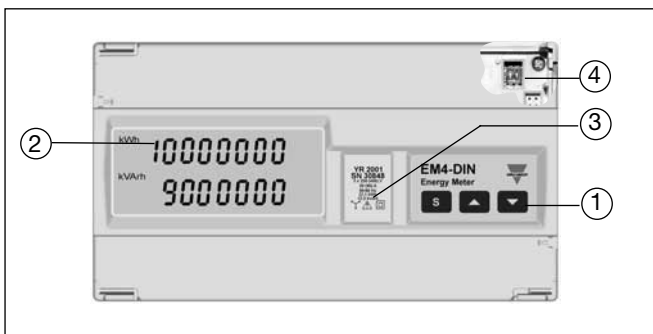

▲ ▼ Keys for:

- values programming;
- function selection;
- displaying the measuring pages.

2. Display

- LCD with alphanumeric indications to:
- display configuration parameters;
 - display all the measured variables.

3. Removable label

It shows the following information:

- year of manufacturing
- serial number
- input voltages and currents
- operating frequency
- kWh measuring class
- kvarh measuring class
- symbols: electric system, attention and dual insulation.

4. Hidden dip-switch

Enable/disable the access to the programming procedure.

1. Key-pad

To program configuration parameters and to display variables.

S S-key to enter programming and confirm selections;

Dimensions and panel cut-out

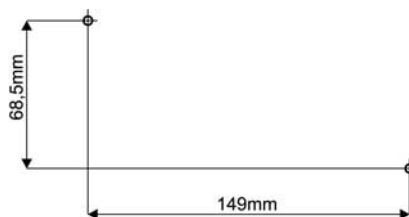
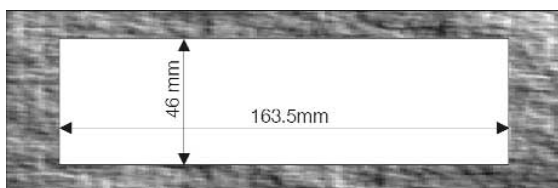
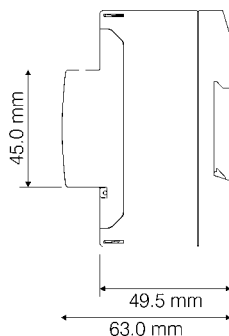
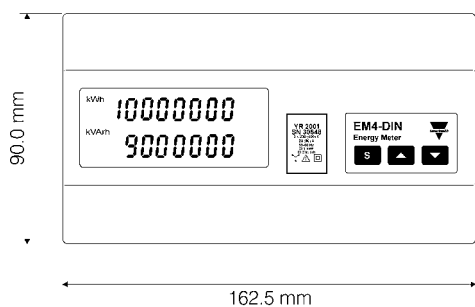

Terminal boards

Open collector dual output module

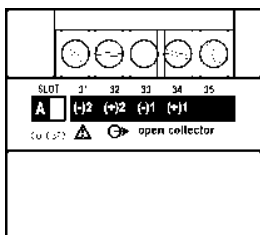

AO 2900

Relay output + open coll. output module

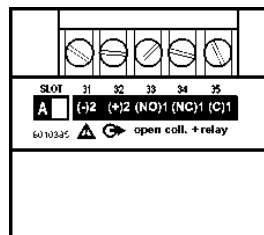

AO 2910

RS485 Serial output module

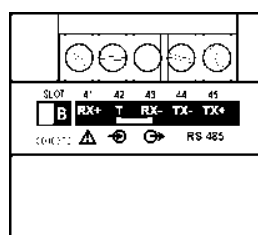

AR 2950

Digital inputs module

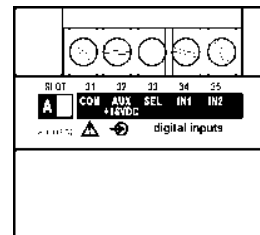

AQ 2940