

Energy Management Energy Meter Type EM10 DIN



- Class 1 (kWh) according to EN62053-21
- Energy meter
- Energy: 5+1 DGT
- Energy measurements: total kWh
- TRMS measurements of distorted sine waves (voltages/currents)
- Self power supply
- Dimensions: 1-DIN module
- Protection degree (front): IP40
- 1 pulse output on request
- MID "annex MI-003" (Measuring Instruments Directive) compliant

Product Description

One-phase energy meter with LCD data displaying; indicated for active energy metering. Housing for DIN-rail mounting, IP40 (front) protection degree. Direct

connection up to 32A. Moreover the meter can be provided with pulse output proportional to the active energy being measured.

How to order EM10 DIN AV8 1 X 01 X

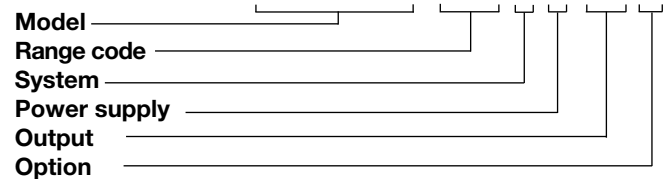

Type Selection

Range code	System	Power supply	Output
AV7: 120V _{LN} AC - 5(32)A (**) (direct connection)	1: 1-phase	X: Self power supply (from 48 to 62Hz). The instrument works on the range from -20% to +20% of the measuring nominal input voltage.	XX: None (*) O1: Pulse type (open collector output) (*)
AV8: 230V _{LN} AC - 5(32)A (*) (direct connection)	Option		
(*) as standard. (**) on request.	X: None (*) P: PTB approval		

Input specifications

Rated inputs Current range (by shunt) Voltage range	System: 1 AV7 and AV8: 5(32)A AV7: 120 VLN AC AV8: 230 VLL AC	Display Type Energie indication	1 line (max: 5+1 DGT) LCD, h 7mm Total: 5+1 DGT
Accuracy (Display) (@25°C ±5°C, R.H. ≤60%, 48 to 62Hz)	lb: 5A, Imax: 32A; Un: 120VLN (-20% +20%) lb: 5A, Imax: 32A; Un: 230VLN (-20% +20%)	LEDs	Red LED (Energy consumption), 1000 pulses/kWh (Max Frequency 16 Hz) according to EN62053-11
AV7 model		Measurements Method	kWh from 0,0 to 99999,9 TRMS measurements of distorted wave forms Direct
AV8 model		Coupling type	Direct
Active energy	Class 1 according to EN62053-21 and MID Annex MI-003 Class B.	Crest factor	lb 5A ≤4 (45A max. peak)
Reference values	lb: 5A, Imax: 32A, 0.1 lb: 0.5A 20mA	Current Overload Continuous For 10ms	32A, @ 50Hz 960A, @ 50Hz
Start up current:		Voltage Overload Continuous For 500ms	1.2 Un 2 Un
Energy additional errors Influence quantities	According to EN62053-21, EN62053-23	Input impedance 120VL-N (AV7) 230VL-N (AV8) 5(32) A (AV7-AV8)	>720KΩ >720KΩ < 0.5VA
Temperature drift	≤200ppm/°C	Frequency	48 to 62 Hz
Sampling rate	1600 samples/s @ 50Hz 1900 samples/s @ 60Hz		

Output specifications

Digital output	(on request)	Pulse duration	≥100ms < 120msec (ON), ≥120ms (OFF), according to EN62052-31
Number of outputs	1	Insulation	By means of optocouplers, 4000 VRMS output to measuring inputs
Type	Open collector, pro- grammable from 0.001 to 1 kWh for each pulse.		
Signal	V _{ON} 1.2 VDC/ max. 100 mA V _{OFF} 30 VDC max.		

General specifications

Operating temperature	-25°C to +55°C (13°F to 131°F) (R.H. from 0 to 90% non-condensing @ 40°C) according to EN62053-21 and EN62053-23	Surge	On current and voltage measuring input circuits: 4kV; According to CISPR 22
Storage temperature	-30°C to +70°C (22°F to 140°F) (R.H. < 90% non- condensing @ 40°C) according to EN62053-21 and EN62053-23	Radio frequency suppression	According to CISPR 22
Installation category	Cat. III (IEC60664, EN60664)	Standard compliance	
Insulation (for 1 minute)	4000 VRMS between mea- suring inputs and digital output (O1).	Safety	IEC60664, IEC61010-1 EN60664, EN61010-1 EN62052-11
Dielectric strength	4000 VRMS for 1 minute	Metrology	EN62053-21, EN62053-23. MID "annex MI-003"
CMRR Noise rejection	100 dB, 48 to 62 Hz	Pulse output Approvals	DIN43864, IEC62053-31 CE, PTB (Revenue Approvals)
EMC	According to EN62052-11 8kV air discharge;	Connections	Screw-type Cable cross-section area
Electrostatic discharges	Test with applied current: 10V/m from 80 to 2000MHz; Test without any applied current: 30V/m from 80 to 2000MHz;	Min. 2.5 mm ² , Max. 10 mm ² (measuring inputs); Other terminals: 1.5 mm ² Min./Max. screws tighten- ing torque: 1 Nm / 4 Nm	
Immunity to irradiated electromagnetic fields	On current and voltage measuring input circuits: 4kV	DIN Housing	
Burst	10V/m from 150KHz to 80MHz	Dimensions (WxHxD)	17.5 x 90 x 67.5 mm
Immunity to conducted disturbances		Material	Nylon PA66, self-extinguishing: UL 94 V-0 DIN-rail
		Mounting	
		Protection degree	
		Front	IP40
		Screw terminals	IP20
		Weight	Approx. 100 g (packing included)

Power supply specifications

Self supplied version	120VLN, 230 VLN (-20% +20%) 48-62Hz	Power consumption	≤ 3VA
------------------------------	--	--------------------------	-------



MID "Annex MI-003" compliance

Accuracy

0.9 $U_n \leq U \leq 1.1 U_n$;
 0.98 $f_n \leq f \leq 1.02 f_n$;
 f_n : 50 or 60Hz;
 $\cos\phi$: 0.5 inductive to
 0.8 capacitive.
 Class B
 I_{st} : 0.025A;
 I_{min} : 0.32A;
 I_{tr} : 0.64A;
 I_{max} : 32A.

Operating temperature

-25°C to +55°C (13°F to
 131°F) (R.H. from 0 to 90%
 non-condensing @ 40°C)

EMC compliance

E2

Used calculation formula

Energy metering

$$kWh_i = \int_{t_1}^{t_2} P_i(t) dt \cong \Delta t \sum_{n_1}^{n_2} P_{nj}$$

Where:

i = considered phase (L1)

P = active power;

t_1, t_2 =starting and ending time points
 of consumption recording;

n = time unit;

Δt = time interval between two
 successive power consumptions;

n_1, n_2 = starting and ending discrete
 time points of consumption recording

Accuracy

kWh, accuracy (RDG) depending on the current

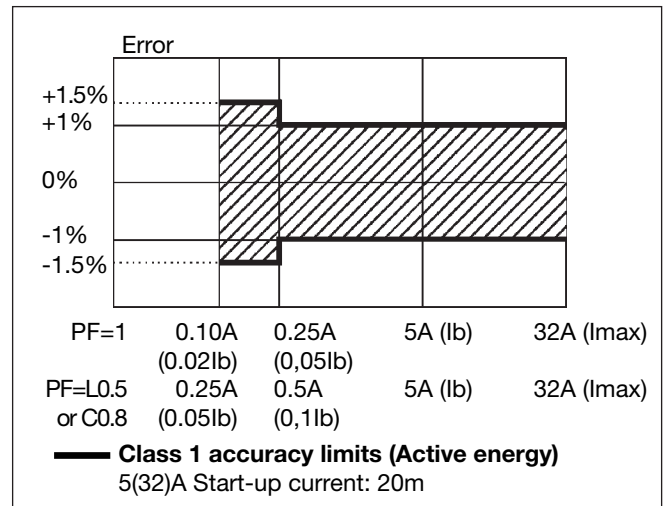

Insulation between inputs and outputs

	Measuring inputs	Open collector output	AC self-power supply
Measuring inputs	-	4kV	0kV
Open collector output	4kV	-	4kV
AC self-power supply	0kV	4kV	-

Wiring diagram and open collector output (O1)

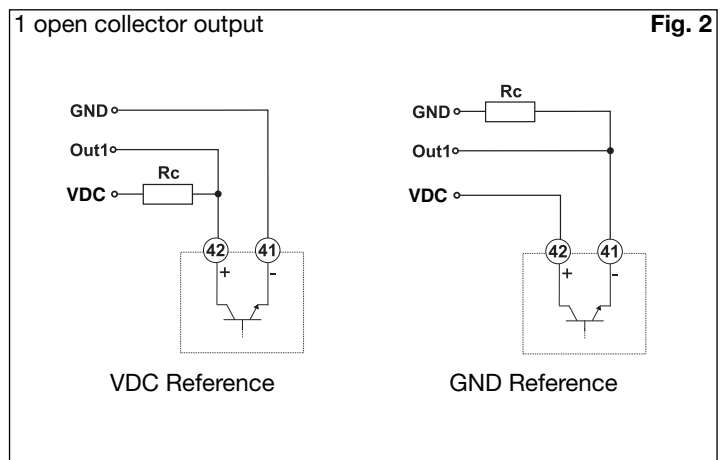
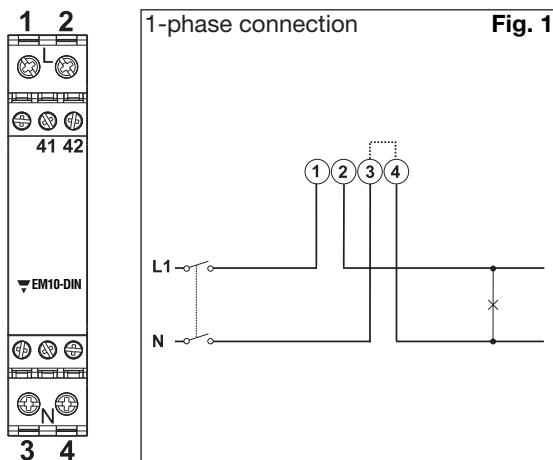

NOTE: The 3 and 4 terminals, in the instrument, are wired together

The load resistances (RC) must be designed so that the close contact current is lower than 100mA; the VDC voltage must be lower than or equal to 30VDC.

Frontal panel description

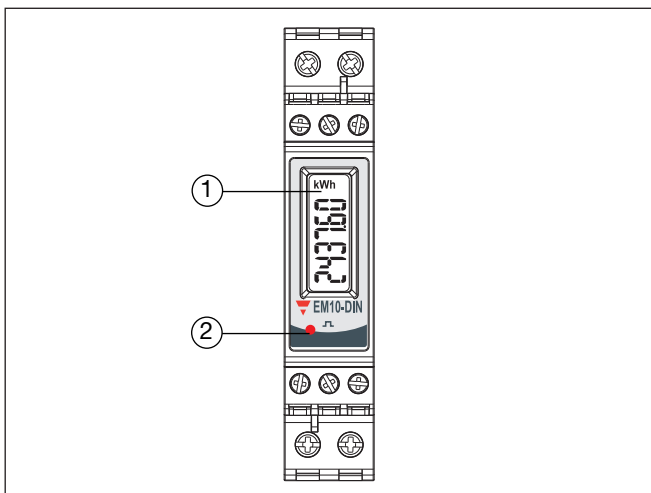

1. **Display**
LCD-type with energy indication.
2. **LED**
Red LED to show the consumed energy.

Dimensions and panel cut-out

